

MAXIMUM PRODUCT LOAD RATING: 100 kg



IMPORTANT:

- **LOAD = WEIGHT OF PLATFORM or BARS + MOUNTING SYSTEM + ACCESSORIES + CARGO**
- **PLEASE REFER TO VEHICLE MANUFACTURER SPECIFICATIONS FOR MAX ROOF LOAD CAPACITY OF VEHICLE. THE LOWEST LOAD RATING APPLIES.**
- **OFFROAD RATING: SCAN QR CODE FOR LOCKNLOAD LOAD RATING GUIDE. REDUCTIONS MAY APPLY.**



IF NO TRACK PROVIDED THIS MOUNTING KIT REQUIRES AN 800 MM OR 1000 MM LONG UNIVERSAL TRACK TO BE INSTALLED FIRST. NOTE: THE UPPER SURFACE OF THE TRACK NEEDS TO BE WITHIN +/- 2 DEGREES OF FLAT, LEFT TO RIGHT.

FIRST TIME INSTALLATION

- Please read instructions carefully before installation.
- Check the contents of kit. Each spine has the last four digits of the kit's part number lasered in. Contact your YAKIMA dealer if any parts appear missing, incorrect or damaged.
- Clean your roof thoroughly prior to fitting the LockNLoad RuggedLine.
- Place these instructions in the vehicle's glove box after installation is complete.

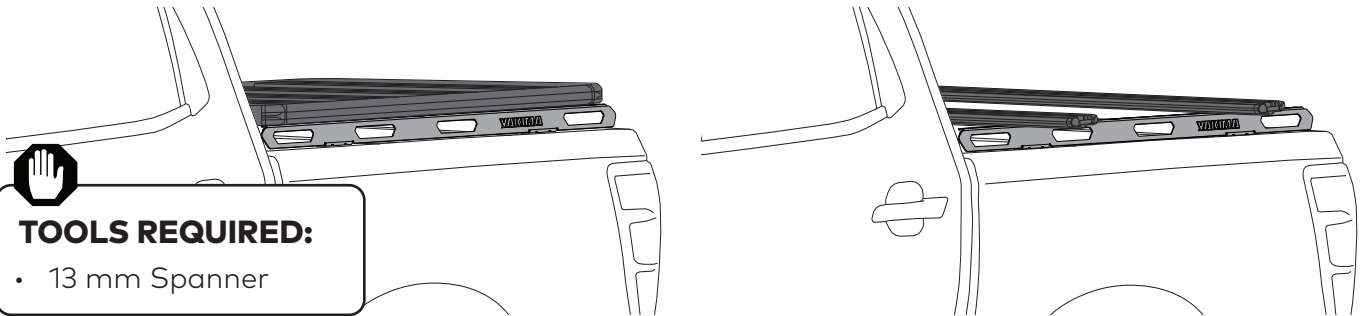

TOOLS REQUIRED:

- 13 mm Spanner

KIT CONTENTS

ITEM	COMPONENT	QTY	ITEM	COMPONENT	QTY
1.	Track 1200 mm Spine LH 2172	x1	8.	M6 Nyloc Nut	x8
2.	Track 1200 mm Spine RH 2172	x1	9.	M6 Flat Wash	x8
3.	Pivot Bracket Assembly	x4	10.	LNL Flush Rail Bar Slot Bolt	x4
4.	M8 Socket Head Capscrew	x4	11.	LNL Flush Rail Bar Slot Plate	x4
5.	M8 Washer	x8	12.	Hex Key Ball End Allen Key 4 mm	x1
6.	M8 Nyloc Nut	x4	13.	Hex Key Ball End Allen Key 6 mm	x1
7.	M6 Self Aligning T-Bolt	x8			

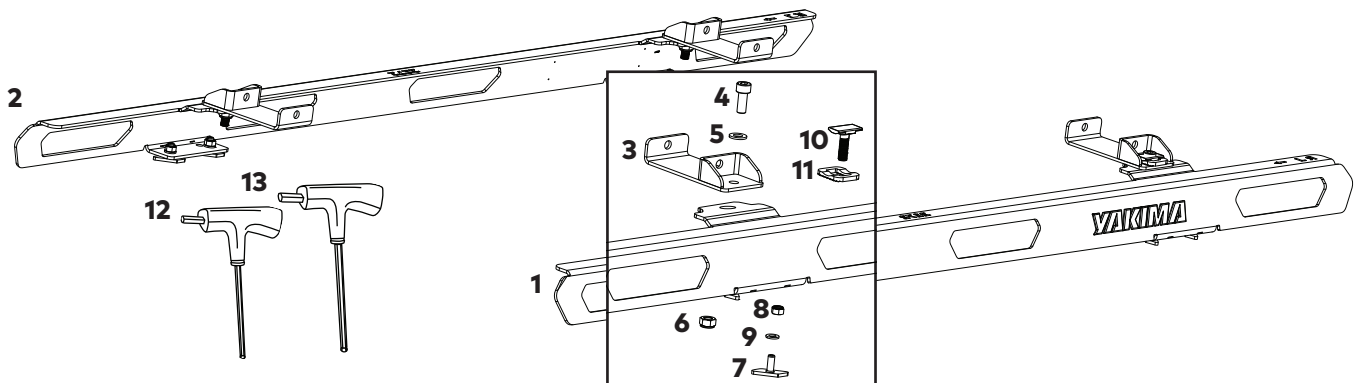

NOTE: ITEMS 3, 4, 5 & 6 ARE FOR USE ON A PLATFORM INSTALLATION. ITEMS 10 & 11 ARE FOR AN LNL BAR INSTALLATION.

RUGGEDLINE SPINE INSTALLATION

1

REMOVE STOPPER

Remove track stopper if applicable

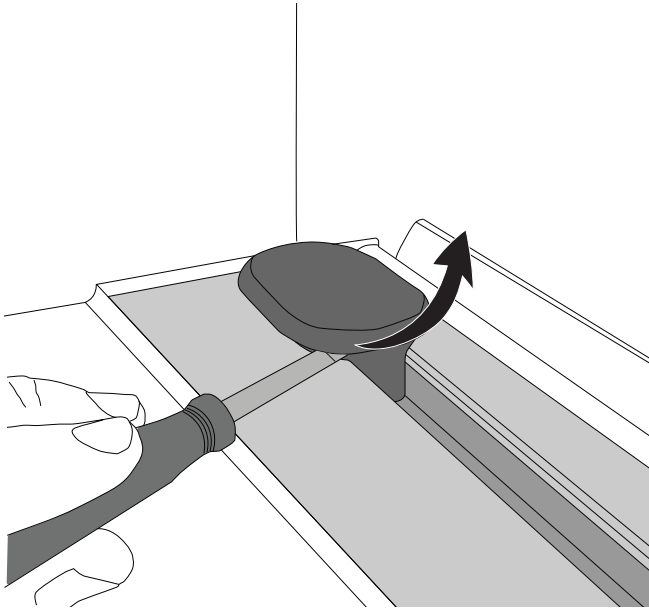

2

INSERT SELF ALIGNING T BOLT

Inset M6 Self Sligning T Bolt into the end of the track and slide into position along the track..

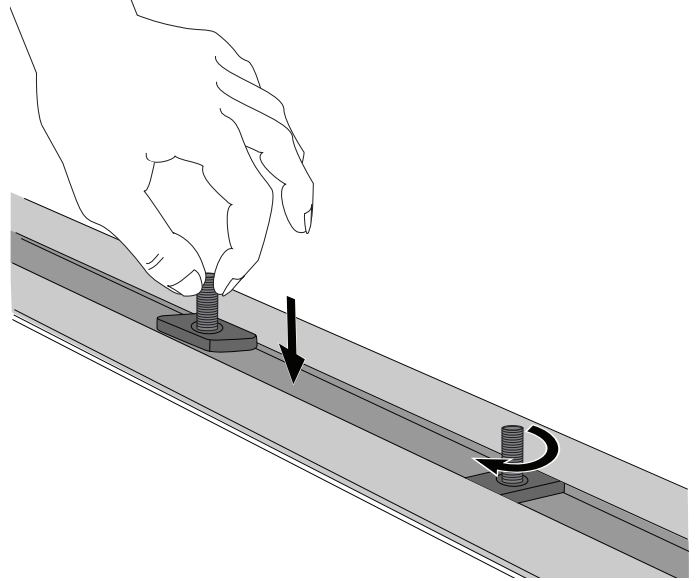

3

POSITION RUGGEDLINE SPINE ON VEHICLE TRAY

Referring to the left-right orientation on top of each blade, carefully place one side RuggedLine Spine onto vehicle tray sides (or canopy) as shown. Line up the mounting holes on the bottom tabs to those exposed on the tray. The tabs are to face in towards the vehicle.

Front of vehicle

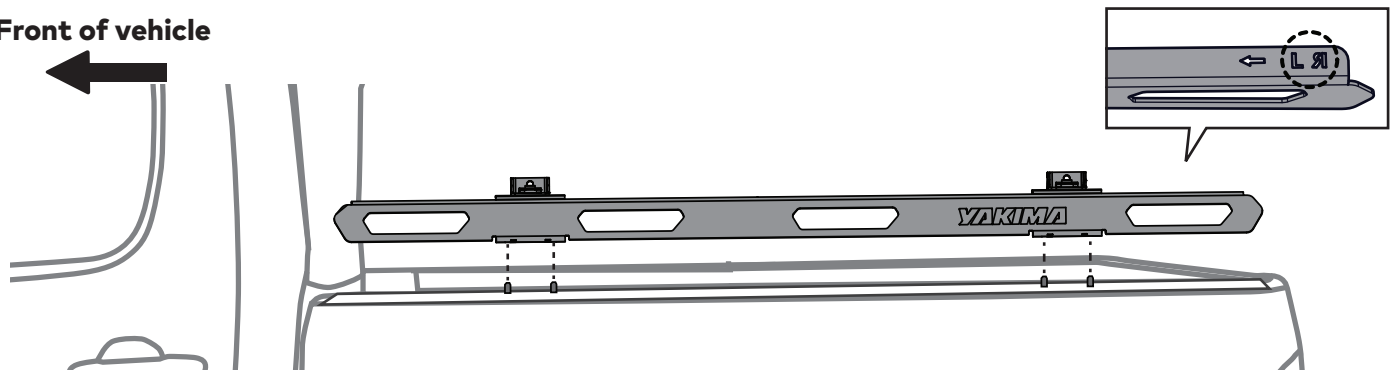

4

ASSEMBLE RUGGEDLINE SPINE HARDWARE

Assemble the M6 washer and M6 Nylock Nut as shown and secure the T-Bolt to the RuggedLine Spine. Ensure the hardware and holes align with the holes on the tray.

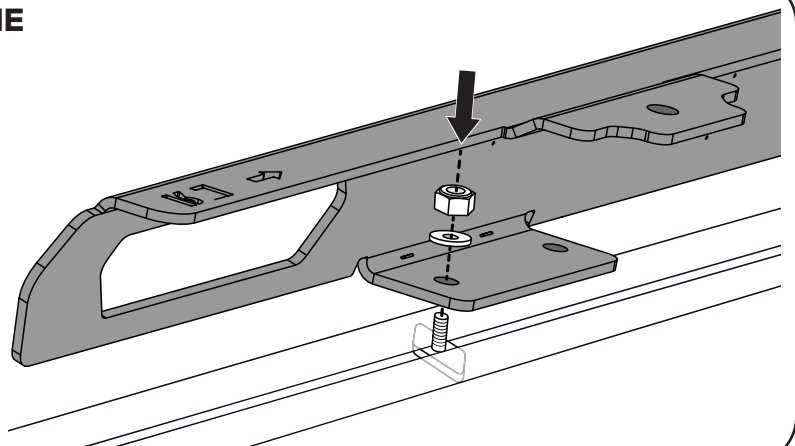

5**TIGHTEN RUGGEDLINE SPINE HARDWARE**

Using the 10 mm Spanner, and avoiding damage to the powder coat, start to carefully secure the RuggedLine Spine by tightening the M6 Nylock nut to 7 Nm into the mounting holes in tray.

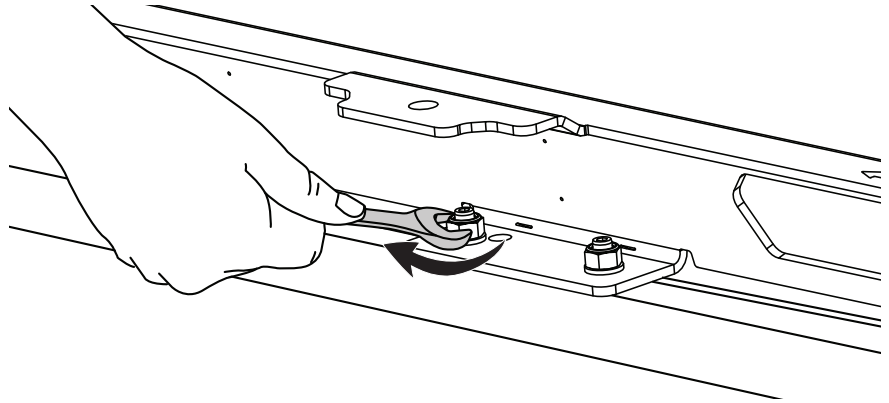

Turn Spanner carefully and be sure not to damage the Nut.

**6****REPEAT STEPS TO OPPOSITE SIDE**

Repeat steps 1-6 for securing opposite side of RuggedLine Spine.

Ensure both spines are securely positioned on vehicle tray. Check each screw is secure before proceeding to install LockNLoad Platform or LockNLoad Bars.

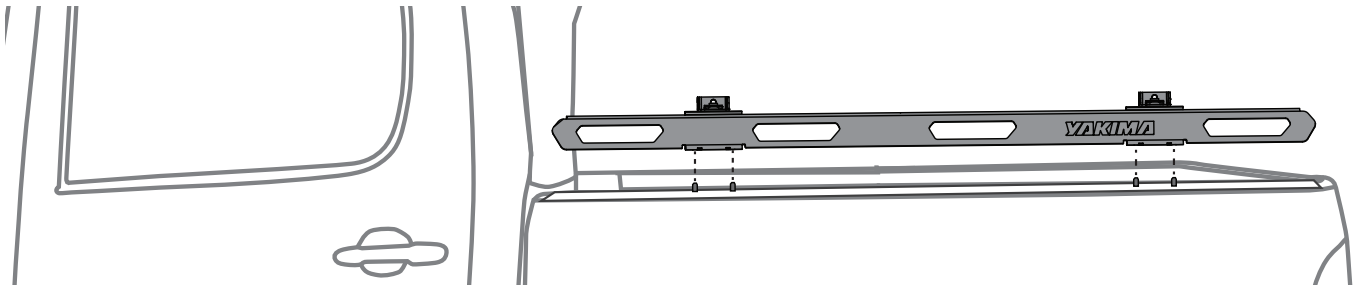

**FOR PLATFORM INSTALLATION, CONTINUE TO PAGE 4
FOR BAR INSTALLATION, CONTINUE TO PAGE 6**

PLATFORM INSTALLATION

1

ASSEMBLE PIVOT BRACKET TO RUGGEDLINE

Assemble Pivot Bracket and M8 hardware as pictured. Complete this for both M8 mounting holes on top of the RuggedLine Spine.

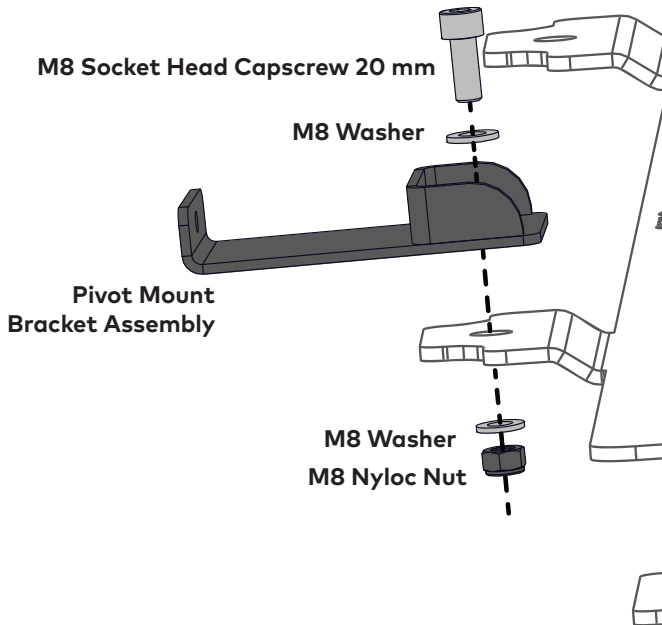

2

SECURE PIVOT BRACKET ASSEMBLIES

Tighten all Capscrews with the provided 6 mm T Handle Ball End Allen Key, and all Nuts with a 13 mm Spanner or a suitable Torque Wrench.

Ensure all Capscrews and Nuts are tightened to 7 Nm.

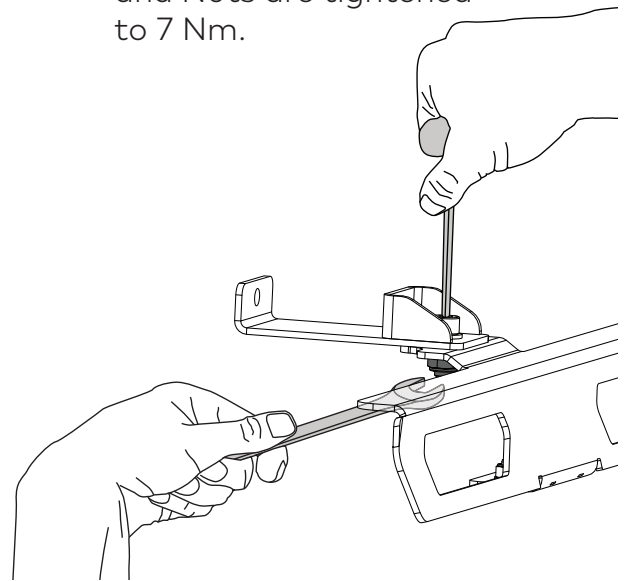

3

INSTALL PLATFORM PIVOT MOUNTS

From the LockNLoad Platform kit (sold separately), position Pivot Mounts into each Pivot Bracket Assembly, lining up the rivnut holes on the Mounts with the holes on the brackets.

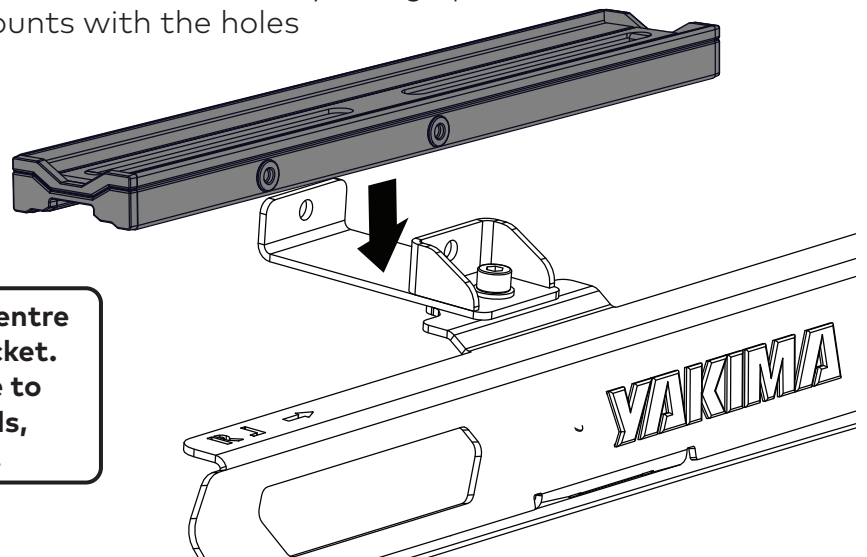

Where possible, always use the centre holes for attaching to Pivot Bracket. If extra clearance is needed due to Platform-to-roof fitment needs, the offset holes can be used.

9

SECURE PLATFORM PIVOT MOUNTS

Secure all Platform Pivot Mounts with 2x 16 mm M6 Capscrews with Washer from LockNLoad Platform kit as shown.

Tighten all Capscrews to 4 Nm with the provided 4 mm Ball End Allen Key or a suitable Torque Wrench.

NOTE - The Pivot Mount assembly will still have movement after securing which is intended.

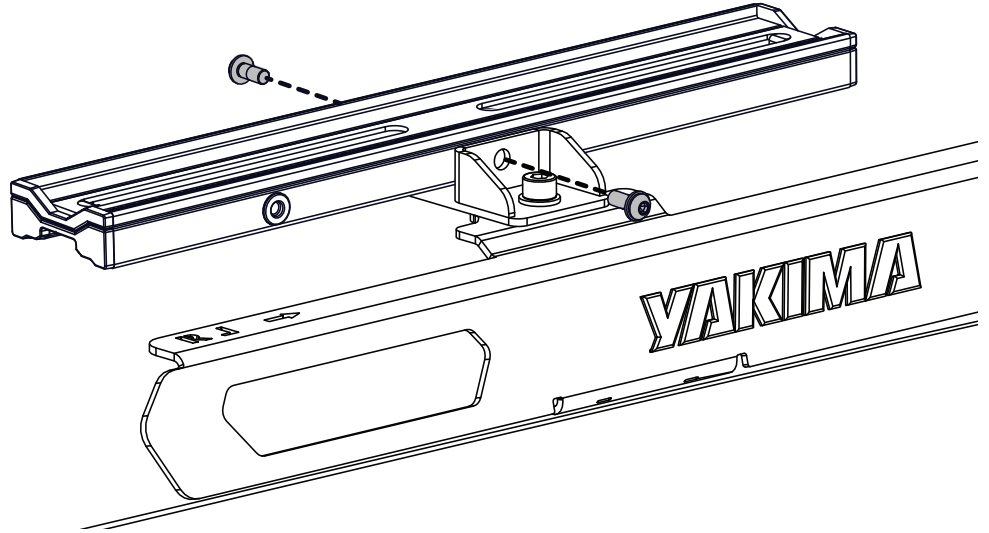

NOW SWITCH TO YOUR LOCKNLOAD PLATFORM INSTRUCTIONS AND CONTINUE FROM THE 'VEHICLE MOUNTING INSTRUCTIONS' PAGE.

LOCKNLOAD BAR INSTALLATION

1

REMOVE END CAPS FROM BARS

From the LockNLoad TrimHD kit (sold separately), remove Plastite Screw from each bar end using a #2 Phillips Head Screwdriver and pull out End Caps from bars. Keep all parts aside for later installation.

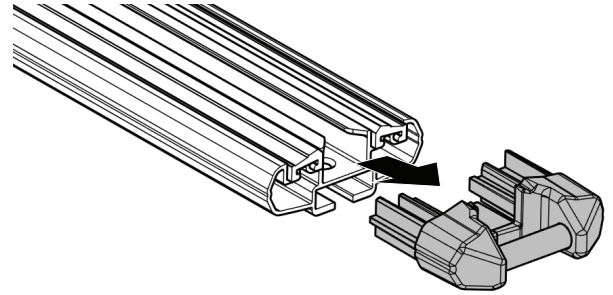
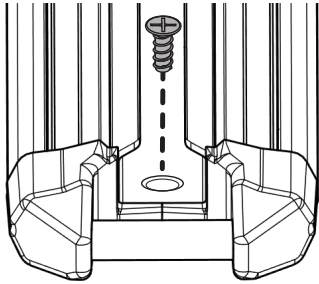

2

REMOVE INFILL

Remove infill from underside of the TrimHD bar.

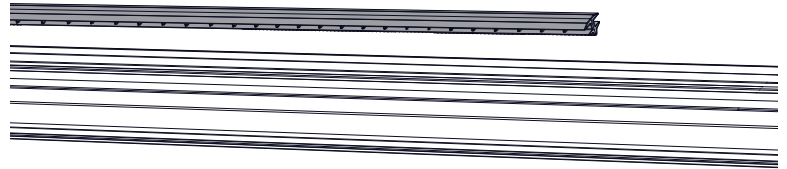
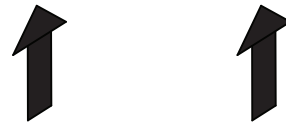

3

BAR FITMENT

Carefully place bar assembly over RuggedLine Spine.

Take care not to damage vehicle. Once positioned, using a tape measure, measure the inside edge distance between the RuggedLine Spine once positioned on the RuggedLine Spine correctly

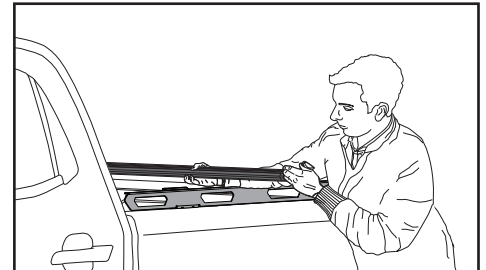
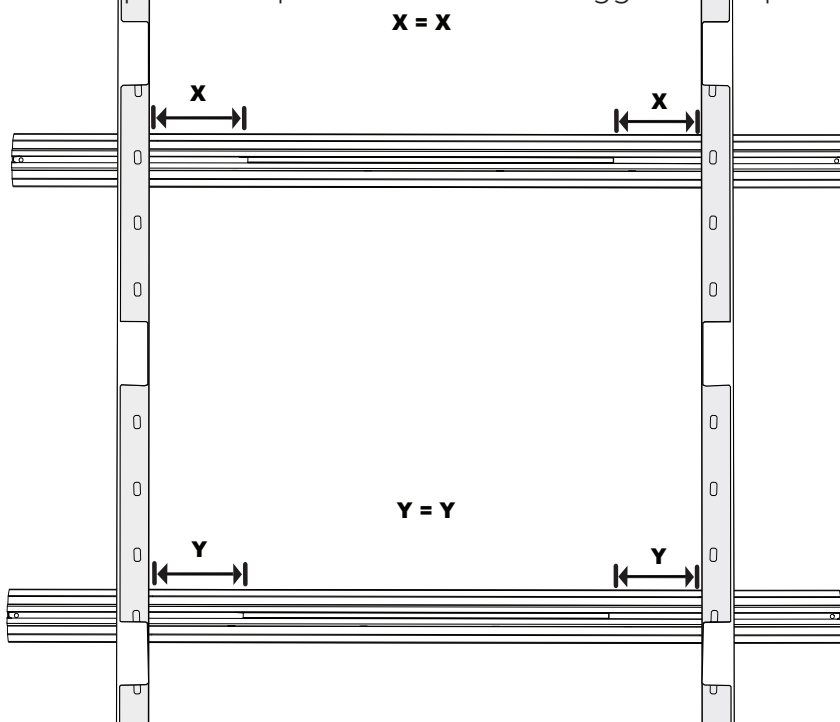

NOTE - Bars and blade shown upside down.

4**BAR FITMENT**

Bar placement should be a minimum of 700 mm apart from one another.

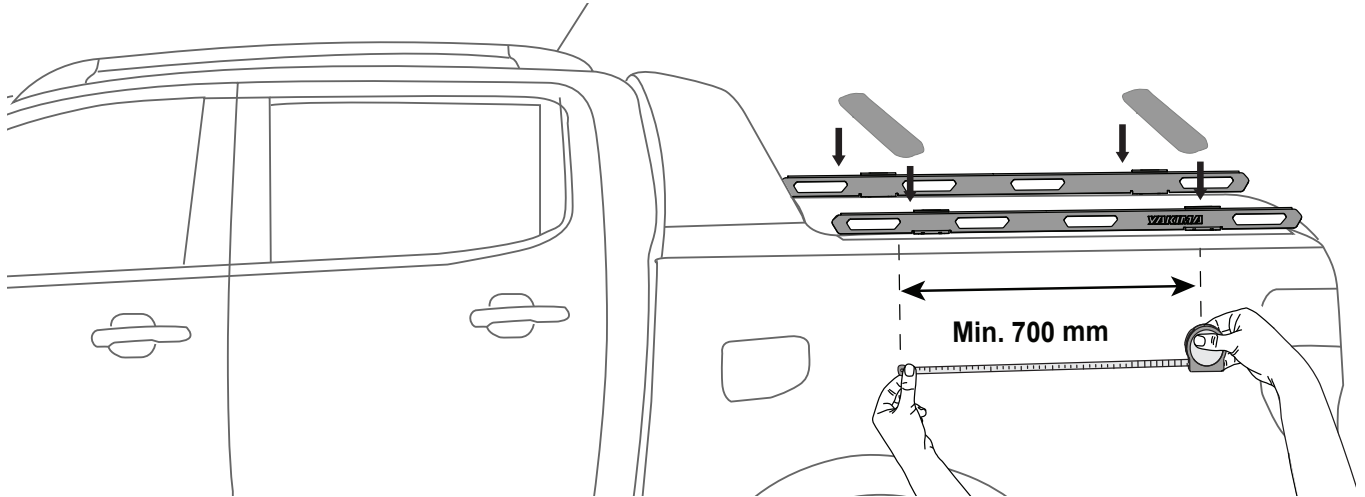
**5****INSERT INFILL**

Cut infill into four pieces according to the measurement taken in Step 3. Insert into underside channel of front and rear bar ends as shown.

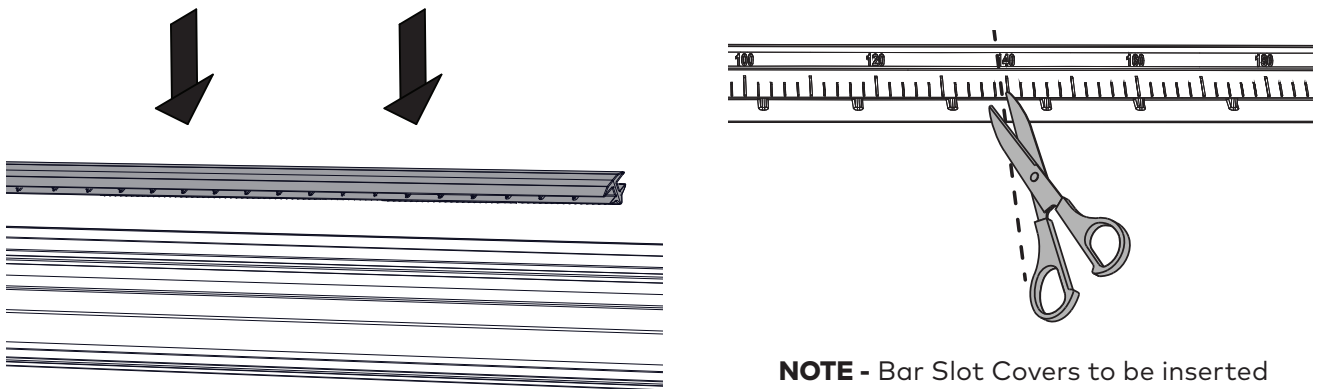

NOTE - Bar Slot Covers to be inserted with flat side visible

6**INSERT SLOT BOLT AND SLOT PALTE**

Insert the Load Bar Slot Plate and the Load Bar Slot Bolt into the RuggedLine Spine. To secure the bolt, use the M8 washer M8 x 1.25 Nylock nut underneath the Spine trim.

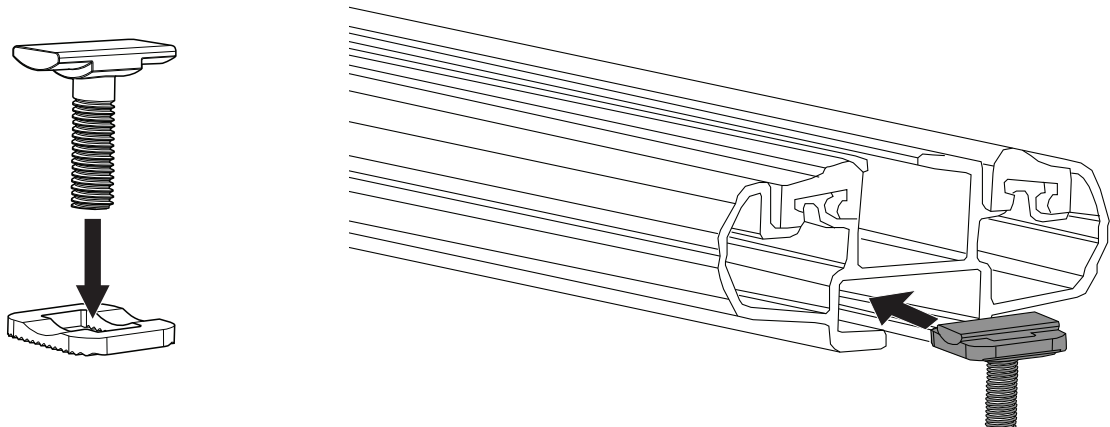

9

INSERT LEGS

Insert the T-Bolt into the Atlas Slide-Away blade.

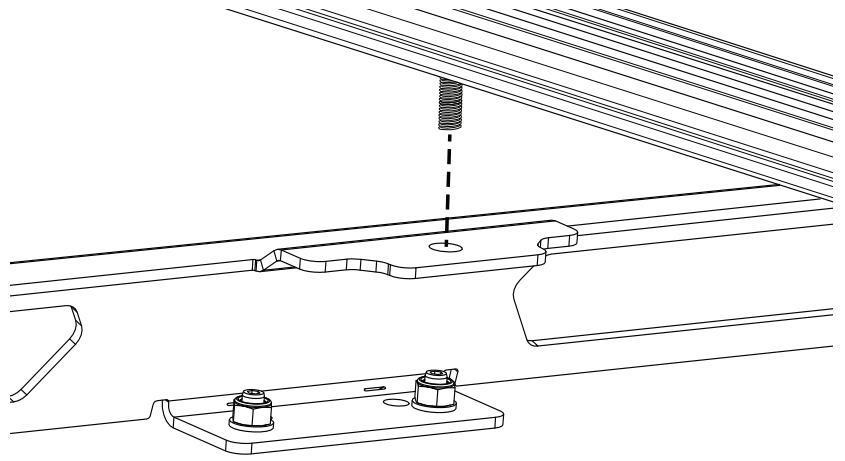

10

SECURE SLOT BOLT AND SLOT PLATE

Using the 10 mm Spanner, secure the plate and bolt to the RuggedLine Spine.

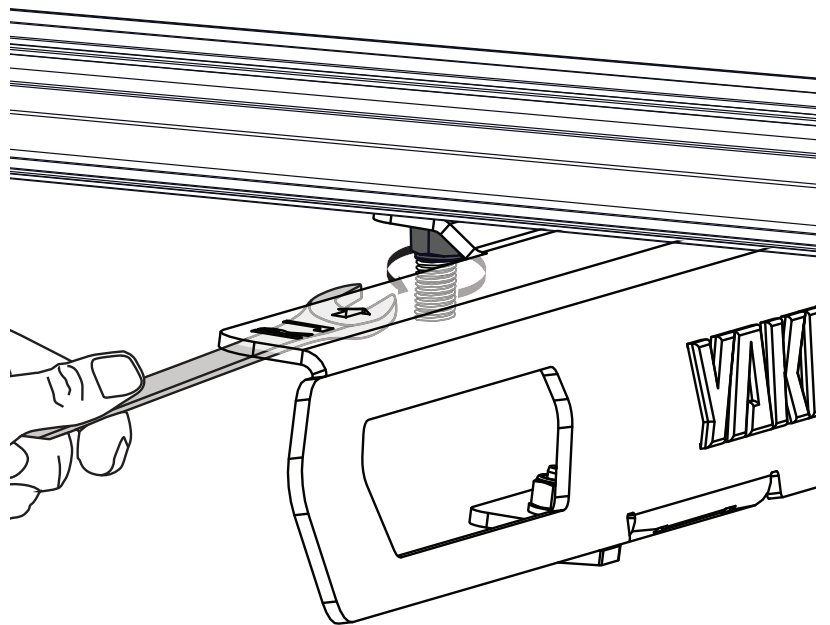
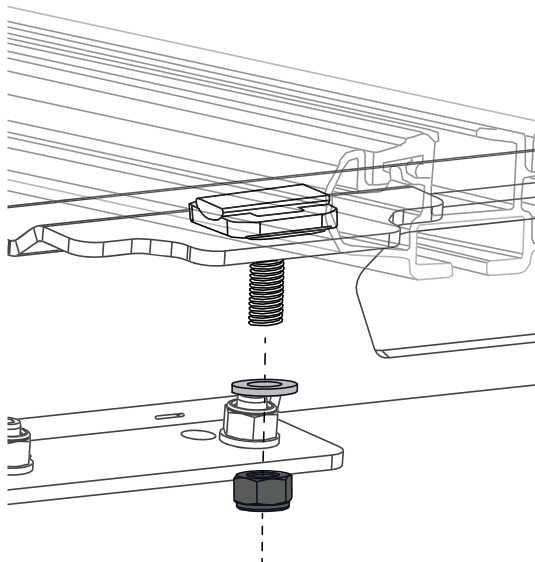

11

CHECK BAR LEGS ARE SECURE

Check all Bar Legs are secure.





www.yakima.com.au
www.yakima.co.nz
www.yakima.com
www.yakima.eu

YAKIMA AUSTRALIA PTY LTD

17 Hinkler Court
Brendale, QLD 4500
Australia
1800 143 548
yakimaglobal.com

YAKIMA PRODUCTS, INC.

4101 Kruse Way
Lake Oswego, OR
97035-2541
USA
888 925 4621
yakima.com/support

ALL CONTENT SUBJECT TO YAKIMA AUSTRALIA PTY LTD COPYRIGHT © 2023