

MAX PLATFORM LOAD RATING:
100 KG (sizes A, B, G, I, K, L & S) 50 KG (size F)
150 KG (sizes C, D, E, H, J, N, P & U)

**PLEASE REFER TO VEHICLE MANUFACTURER SPECIFICATIONS FOR MAX ROOF LOAD RATING
(TOTAL LOAD EQUALS WEIGHT OF LEGS + PLATFORM + CARGO)**

FIRST TIME INSTALLATION

- Please read instructions carefully before installation.
- Check the contents of kit. Contact your YAKIMA dealer if any parts appear missing or damaged.
- Clean your vehicle roof prior to fitting the LockNLoad Platform.
- Use caution when handling Platform Sides, Ends and Slats as sharp edges may be present.
- Images throughout show a 7 Slat Platform, indicative of Platform sizes A and B. Please note other Platforms will have differing amounts of slats and hardware.
- Place these instructions in the vehicle's glove box after installation is complete.



TOOLS REQUIRED:

- 4 mm Ball End Allen Key or Torque Wrench
- 13 mm Socket Wrench or Spanner

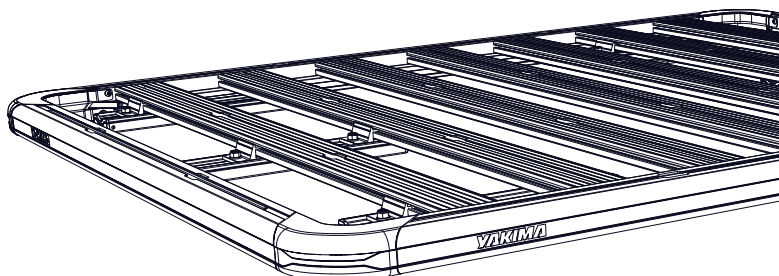

KIT CONTENTS

| ITEM | COMPONENT | Platform | Platform | Platform | Platform | Platform |
|------|---------------------------------|----------------------------|----------------------------|----------------------------|----------------------------|----------------------------|
| | | A 1240 x 1530 mm | B 1380 x 1540 mm | C 1380 x 1930 mm | D 1425 x 2130 mm | E 1235 x 2130 mm |
| 1. | Platform Side Left & Right | x2 | x2 | x2 | x2 | x2 |
| 2. | Platform Corner | x4 | x4 | x4 | x4 | x4 |
| 3. | Slat | x7 | x7 | x9 | x10 | x10 |
| 4. | M6 Tee Nut | x8 | x8 | x8 | x8 | x8 |
| 5. | M6 Capscrew 25 mm with Washer | x10 | x10 | x10 | x10 | x10 |
| 6. | M6 Capscrew 16 mm with Washer | x36 | x36 | x48 | x48 | x48 |
| 7. | Platform Support Front and Rear | x2 | x2 | x2 | x2 | x2 |
| 8. | Slat Clamp | x14 | x14 | x18 | x18 | x18 |
| 9. | Mounting Block | x4 | x4 | x6 | x6 | x6 |
| 10. | M8 T Bolt | x8 | x8 | x12 | x12 | x12 |
| 11. | M6 Plastite Capscrew 20 mm | x8 | x8 | x8 | x8 | x8 |
| 12. | M8 Nyloc Nut | x14 | x14 | x18 | x18 | x18 |
| 13. | M8 Washer | x14 | x14 | x18 | x18 | x18 |
| 14. | Spare Fasteners Pack | x1 | x1 | x1 | x1 | x1 |
| 15. | Platform Corner Brace | x4 | x4 | x4 | x4 | x4 |
| 16. | Platform Rear | x1 | x1 | x1 | x1 | x1 |
| 17. | Platform Front | x1 | x1 | x1 | x1 | x1 |
| 18. | Leg Mounting Bracket | x4 | x4 | x6 | x6 | x6 |
| 19. | Square T Bolt M8 x 25 | x6 | x6 | x6 | x6 | x6 |

KIT CONTENTS

| ITEM | COMPONENT | Platform | Platform | Platform | Platform | Platform | |
|------|---------------------------------|-------------------------------|-------------------------------|-------------------------------|-------------------------------|-------------------------------|-------------------------------|
| | | F 1570 x 805 mm | G 1570 x 1400 mm | H 1570 x 2128 mm | I 1650 x 1400 mm | J 1650 x 1928 mm | |
| 1. | Platform Side Left & Right | x2 | x2 | x2 | x2 | x2 | |
| 2. | Platform Corner | x4 | x4 | x4 | x4 | x4 | |
| 3. | Slat | x3 | x6 | x10 | x6 | x9 | |
| 4. | M6 Tee Nut | x8 | x8 | x8 | x8 | x8 | |
| 5. | M6 Capscrew 25 mm with Washer | x10 | x10 | x10 | x10 | x10 | |
| 6. | M6 Capscrew 16 mm with Washer | x18 | x32 | x52 | x32 | x52 | |
| 7. | Platform Support Front and Rear | x1 | x2 | x2 | x2 | x2 | |
| 8. | Slat Clamp | x12 | x14 | x18 | x14 | x18 | |
| 9. | Mounting Block | x2 | x4 | x6 | x4 | x6 | |
| 10. | M8 T Bolt | x8 | x8 | x12 | x8 | x12 | |
| 11. | M6 Plastite Capscrew 20 mm | x8 | x8 | x8 | x8 | x8 | |
| 12. | M8 Nyloc Nut | x12 | x14 | x18 | x14 | x18 | |
| 13. | M8 Washer | x12 | x14 | x18 | x14 | x18 | |
| 14. | Spare Fasteners Pack | x1 | x1 | x1 | x1 | x1 | |
| 15. | Platform Corner Brace | x4 | x4 | x4 | x4 | x4 | |
| 16. | Platform Rear | x1 | x1 | x1 | x1 | x1 | |
| 17. | Platform Front | x1 | x1 | x1 | x1 | x1 | |
| 18. | Leg Mounting Bracket | x4 | x4 | x6 | x4 | x6 | |
| 19. | Square T Bolt M8 x 25 | x4 | x6 | x6 | x6 | x6 | |
| ITEM | COMPONENT | Platform | Platform | Platform | Platform | Platform | Platform |
| | | K 1236 x 1400 mm | L 1376 x 1400 mm | N 1376 x 2128 mm | P 1300 x 1928 mm | S 1485 x 1528 mm | U 1485 x 2128 mm |
| 1. | Platform Side Left & Right | x2 | x2 | x2 | x2 | x2 | x2 |
| 2. | Platform Corner | x4 | x4 | x4 | x4 | x4 | x4 |
| 3. | Slat | x6 | x6 | x10 | x9 | x7 | x10 |
| 4. | M6 Tee Nut | x8 | x8 | x8 | x8 | x8 | x8 |
| 5. | M6 Capscrew 25 mm with Washer | x10 | x10 | x10 | x10 | x10 | x10 |
| 6. | M6 Capscrew 16 mm with Washer | x32 | x32 | x52 | x48 | x36 | x52 |
| 7. | Platform Support Front and Rear | x2 | x2 | x2 | x2 | x2 | x2 |
| 8. | Slat Clamp | x14 | x14 | x18 | x18 | x14 | x18 |
| 9. | Mounting Block | x4 | x4 | x6 | x6 | x4 | x6 |
| 10. | M8 T Bolt | x8 | x8 | x12 | x12 | x8 | x12 |
| 11. | M6 Plastite Capscrew 20 mm | x8 | x8 | x8 | x8 | x8 | x8 |
| 12. | M8 Nyloc Nut | x14 | x14 | x18 | x18 | x14 | x18 |
| 13. | M8 Washer | x14 | x14 | x18 | x18 | x14 | x18 |
| 14. | Spare Fasteners Pack | x1 | x1 | x1 | x1 | x1 | x1 |
| 15. | Platform Corner Brace | x4 | x4 | x4 | x4 | x4 | x4 |
| 16. | Platform Rear | x1 | x1 | x1 | x1 | x1 | x1 |
| 17. | Platform Front | x1 | x1 | x1 | x1 | x1 | x1 |
| 18. | Leg Mounting Bracket | x4 | x4 | x6 | x6 | x4 | x6 |
| 19. | Square T Bolt M8 x 25 | x6 | x6 | x6 | x6 | x6 | x6 |

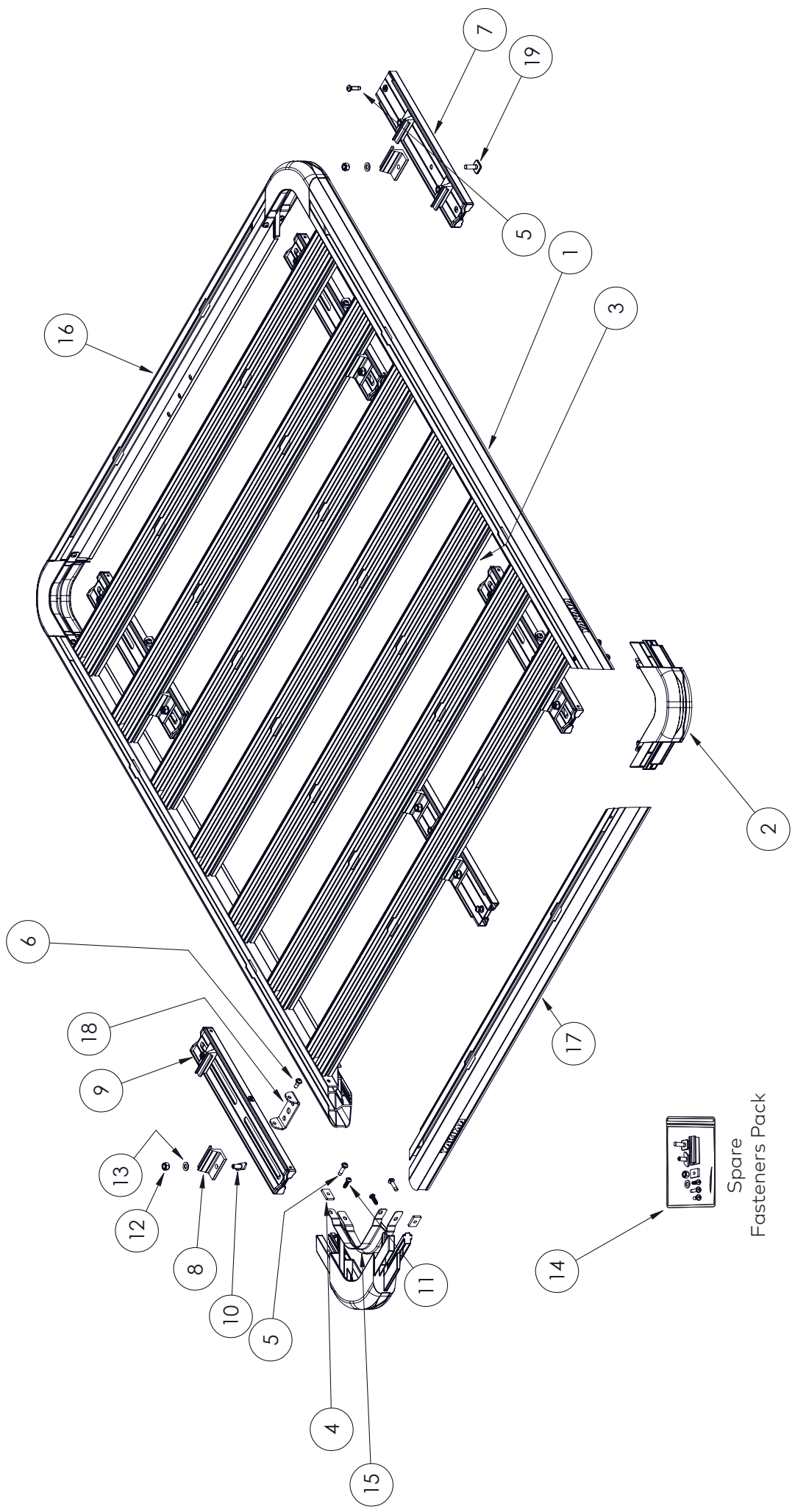

NOTE - 7 Slat Platform shown, indicative of Platform sizes A and B.

PLATFORM ASSEMBLY

1 INSERT NUTS INTO PLATFORM CORNERS

Insert 2 x M6 Tee Nuts into each Corner piece as shown.

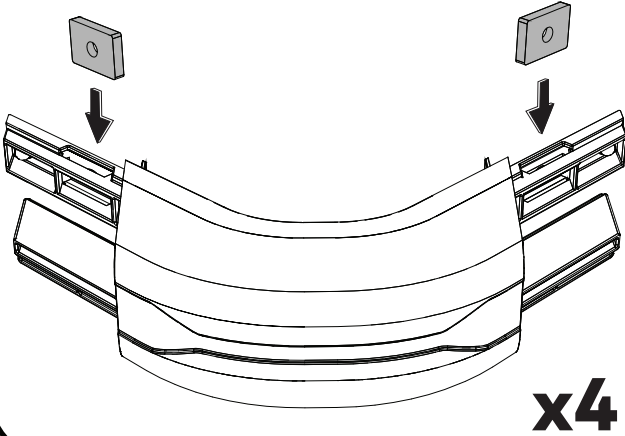

2 FLIP SIDES & ENDS UPSIDE DOWN

Clear a work area that will be large enough for the Platform when fully assembled.

Place Platform Ends and Sides upside down in this work space (use logos as reference).



TIP - To prevent scratching, place a blanket (or the Platform's carton, flattened out) over the work area.

3a ASSEMBLE PLATFORM ENDS

Insert Platform Corners into Platform Ends. Push firmly until fully inserted.

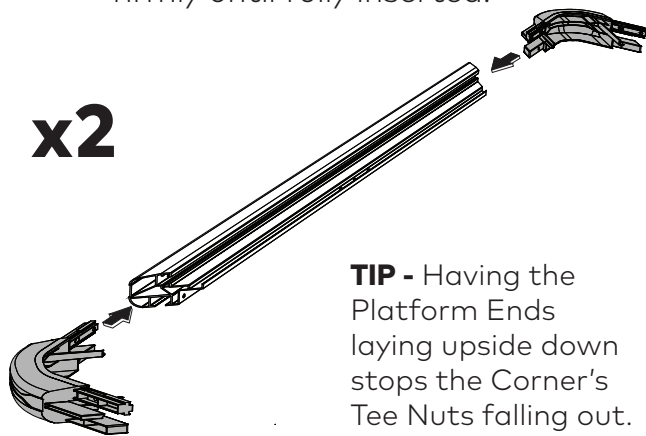

TIP - Having the Platform Ends laying upside down stops the Corner's Tee Nuts falling out.

3b ASSEMBLE PLATFORM ENDS AND SIDES

Take one of the Platform End assemblies created in Step 3a, and fit the Platform Sides to the corners. Push firmly until fully inserted.

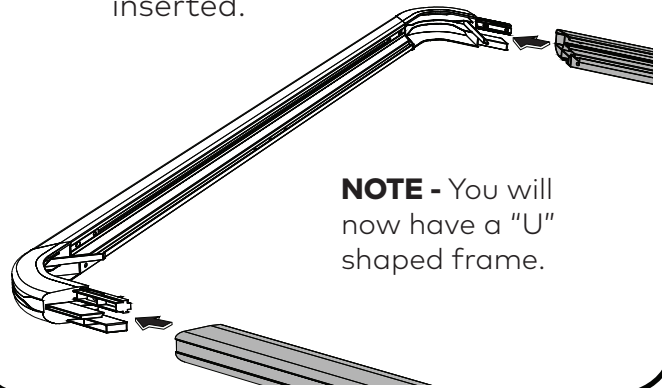

3c COMPLETE PLATFORM PERIMETER

Connect remaining End assembly to the Sides as shown below - this completes the four sides of the Platform's perimeter.

Leave Platform Perimeter **upside down** for Steps 4-7.

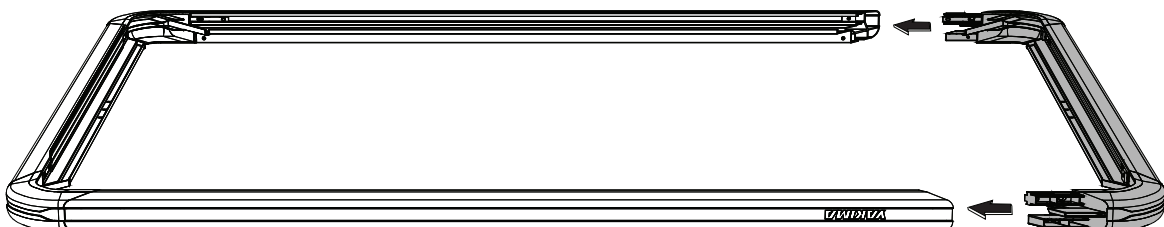

4**INSTALL CORNER BRACES**

Secure Corner Braces to all four Corner Pieces using 2 x M6 Capscrew 25 mm with Washer and 2 x M6 Plastite Capscrew 20 mm as shown. Tighten all screws to 4 Nm with a 4 mm Ball End Allen Key or a suitable Torque Wrench.

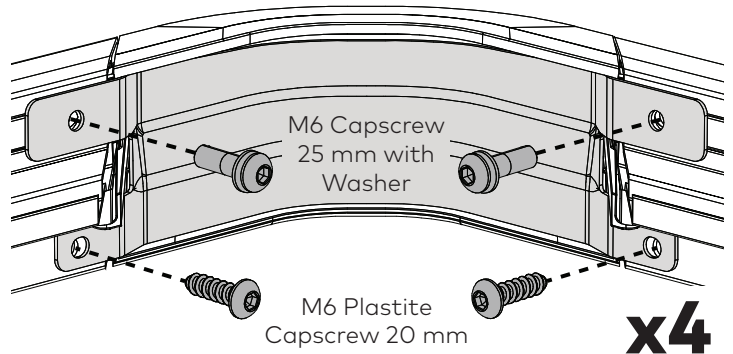
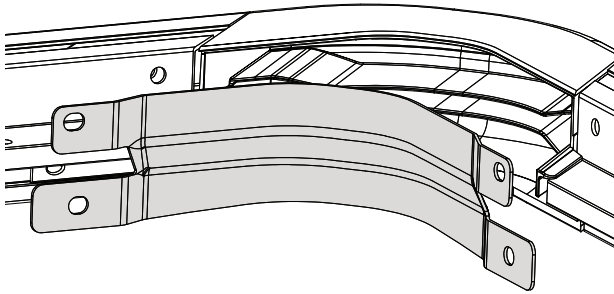
**5****INSTALL SLATS**

Flip Slats over.

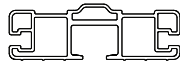

One-by-one, slide Slats into position underneath the perimeter's inside lip. Line up rivnuts on each end of the Slat with the holes in the Platform Sides.

Repeat until all Slats are in place.

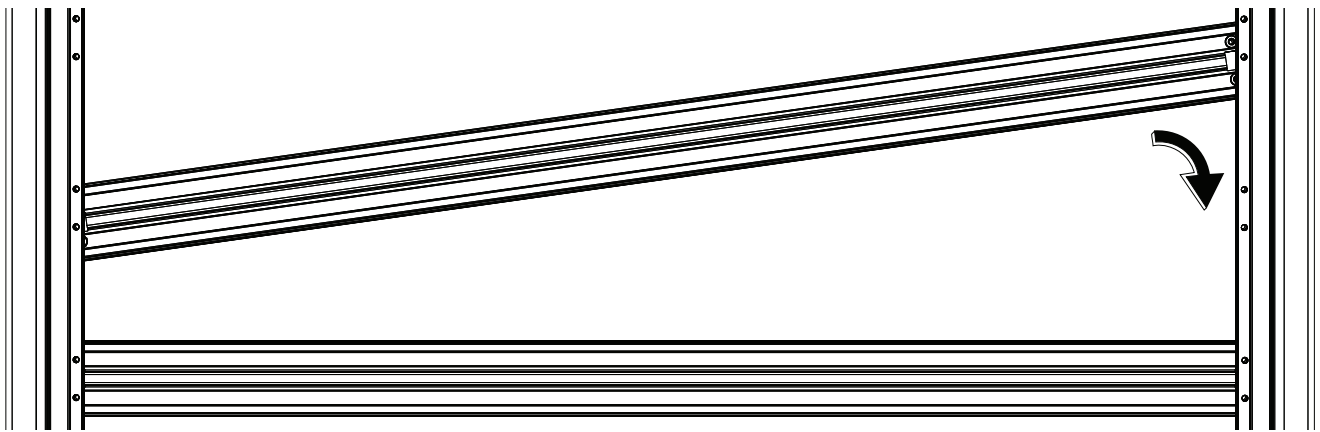
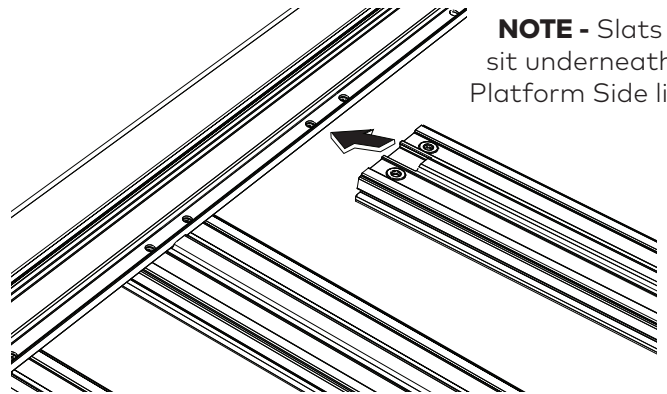
**6****SECURE SLATS**

Starting from the middle Slat and working outwards, secure each Slat end using 2 x M6 Capscrew 16 mm with Washer as shown.

Tighten all screws to 4 Nm with a 4 mm Ball End Allen Key or a suitable Torque Wrench.

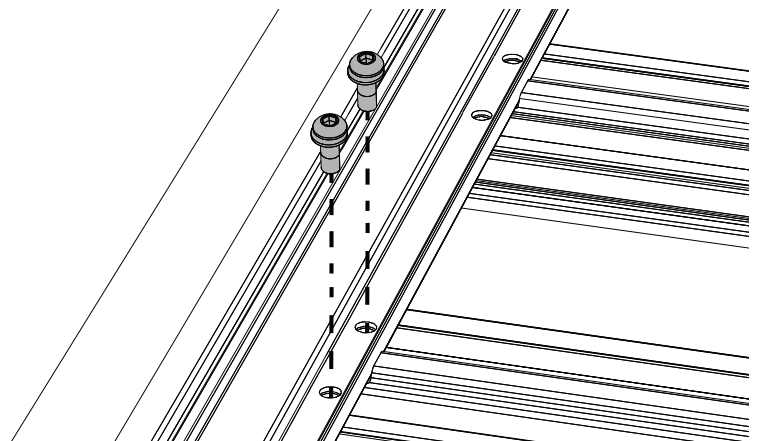

7

POSITION PLATFORM SUPPORTS

Carefully flip Platform over so it faces right way up.



Position the Platform Supports underneath the centre of the Front and Rear Platform Ends. The flat end of the Support sits under the lip.

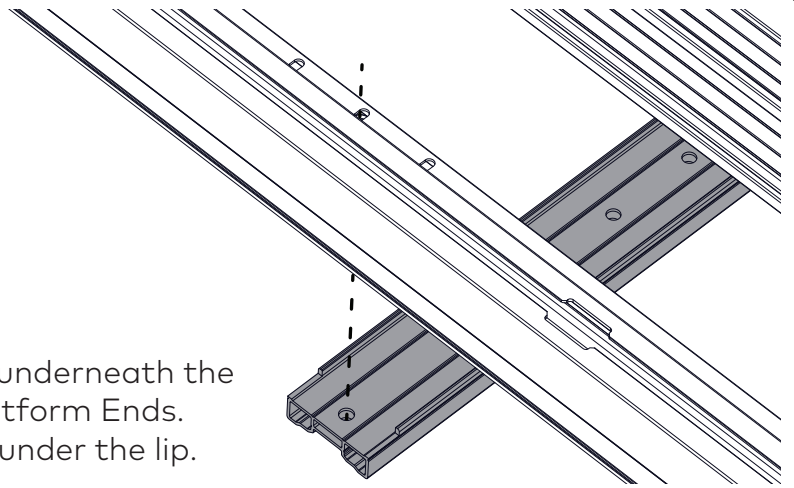

The Platform Supports ideally should be fixed using the centre of the three holes. However, these can be offset left or right depending on the vehicle's roof or usage requirements. For instance, to prevent interference with an antenna in the centre of a vehicle roof (e.g. Nissan Navara NP300, Ford Ranger).

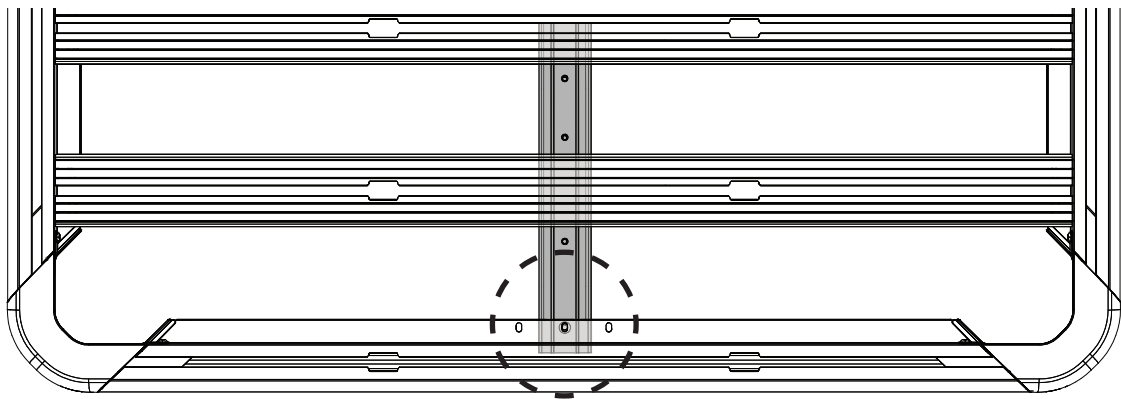

x2

8

SECURE PLATFORM SUPPORTS

Position a Slat Clamp on each side of the Slat that the Support passes under as shown.

Secure Platform Support to Platform End using one M6 x 25 mm Capscrew with Washer through the middle Platform End hole.

Secure Platform Support to Slats using one M8 x 25 mm Square T-Bolt underneath, one M8 Washer and M8 Nyloc Nut on top of each Slat Clamp as shown.

Tighten all screws to 7 Nm with a 13 mm Socket Wrench or Spanner. Repeat for other end.

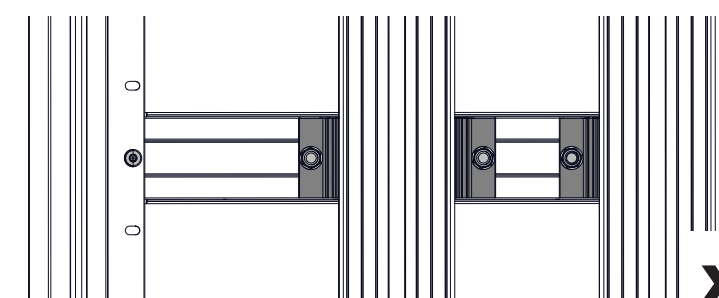
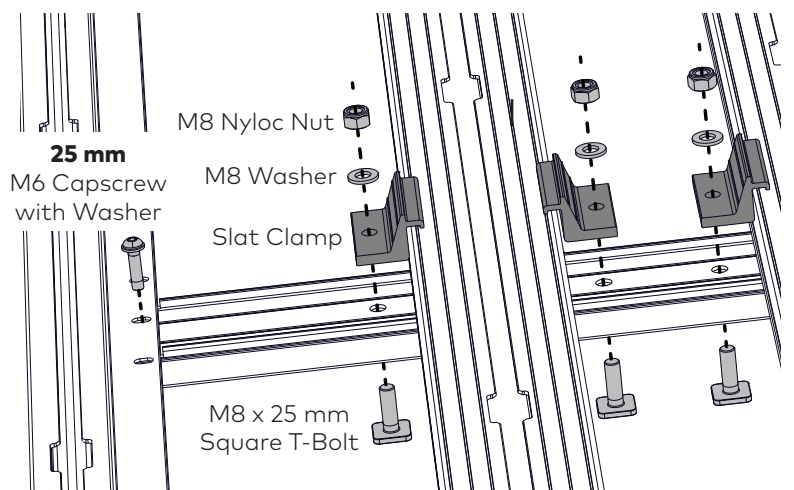

x2

9

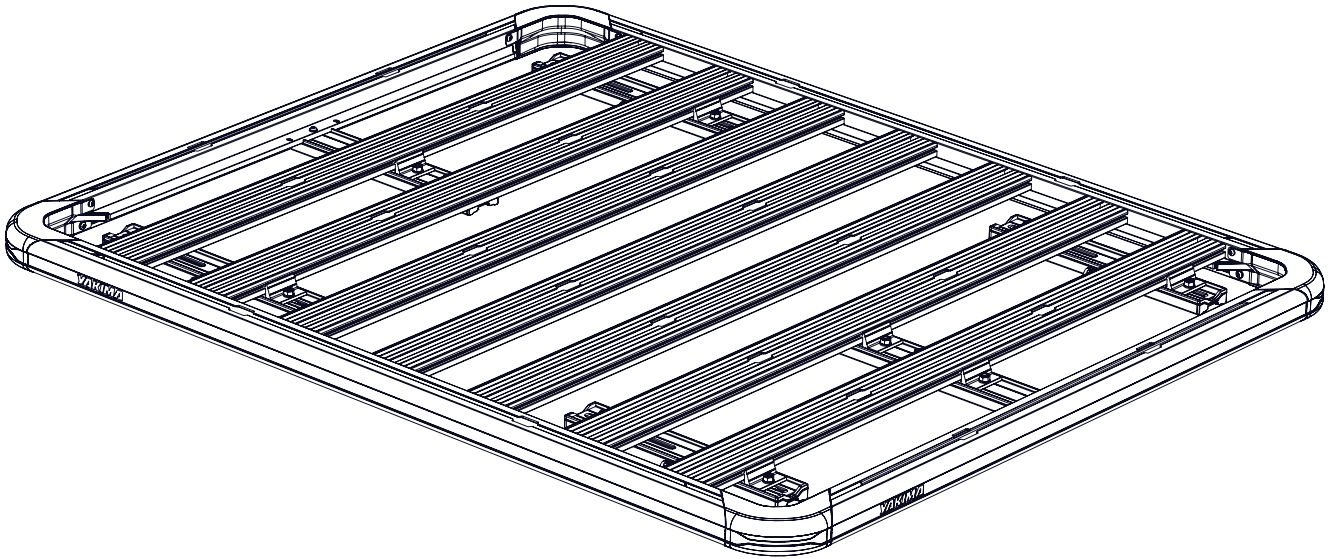

PLATFORM ASSEMBLY COMPLETE

Check that Platform has been assembled correctly as per the installation instructions.

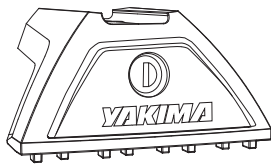
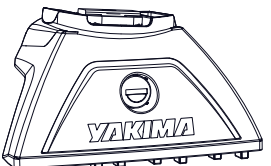
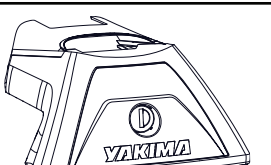

NOTE - 7 Slat Platform shown - indicative of sizes A and B.

PLEASE REFER TO STEPS IN TABLE BELOW FOR LEG MOUNTING INSTRUCTIONS RELATING TO YOUR SPECIFIC LEG KIT

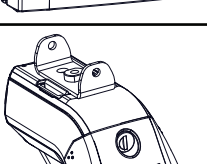
| NAME | IMAGE | LEG PACK PART NUMBER | PAGE | STEPS |
|-------------------------|-------------------------------------------------------------------------------------|-----------------------------|--------|--------|
| Fixed & Track Mount |  | 8000142 / 8000143 / 8000144 | 8 | 1 to 4 |
| Fixed & Track Mount mk2 |  | 9800302 / 9800304 / 9800306 | 9 & 10 | 1 to 4 |
| Flush Rail |  | 8002001 with 8000367 | 9 & 10 | 1 to 4 |
| Gutter Mount |  | 8000351 / 8000352 / 8000353 | 8 | 1 to 4 |
| Raised Rail |  | 8000389 | 10 | 4 only |

LEG MOUNTING INSTRUCTIONS

1 REMOVE LEG COVERS

Using the keys supplied in the LockNLoad Leg Kit (sold separately), remove all Leg Covers.

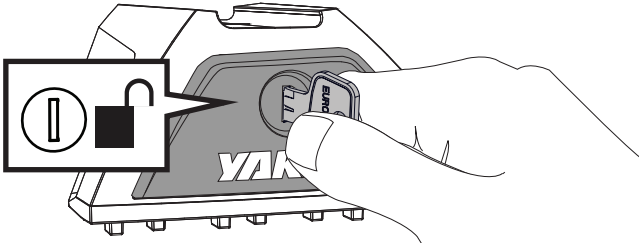

2 ASSEMBLE SCREWS

From the Leg Kit, assemble one M8 Washer onto each M8 Set Screw 16 mm as shown.

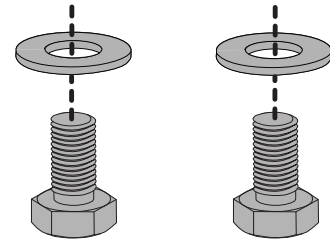

3 ASSEMBLE LEGS

Assemble each Leg as shown using one Leg Mounting Bracket (from Platform Kit), one Nut Plate (from Leg Kit), and the two screw assemblies from the previous step.

Tighten all M8 Set Screws to 7 Nm using a 13 mm Socket Wrench or Spanner.

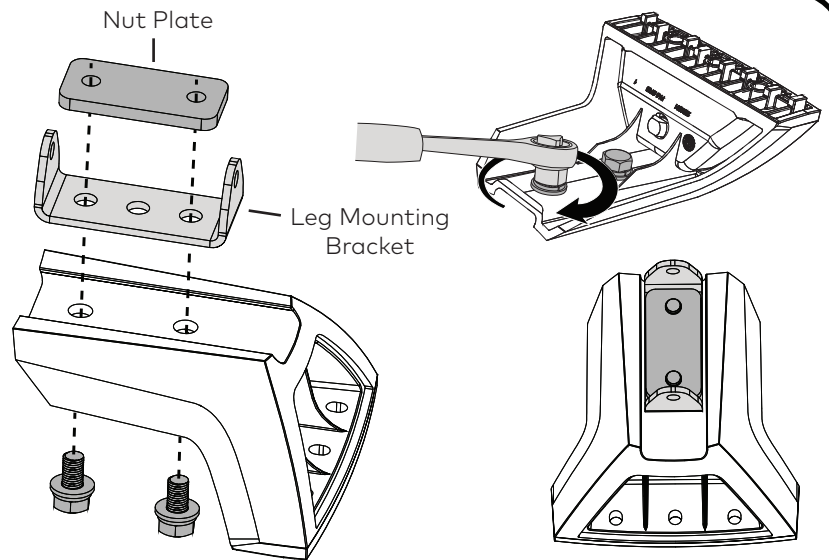

4 INSTALL MOUNTING BLOCKS

Place a Mounting Block (from Platform Kit) on top of each Leg assembly, lining up the rivnut holes on Mounting Block with holes on tabs of Leg Mounting Bracket.

Secure with two M6 Capscrews 16 mm with Washer as shown.

Tighten all Capscrews to 4 Nm with a 4 mm Ball End Allen Key or a suitable Torque Wrench.

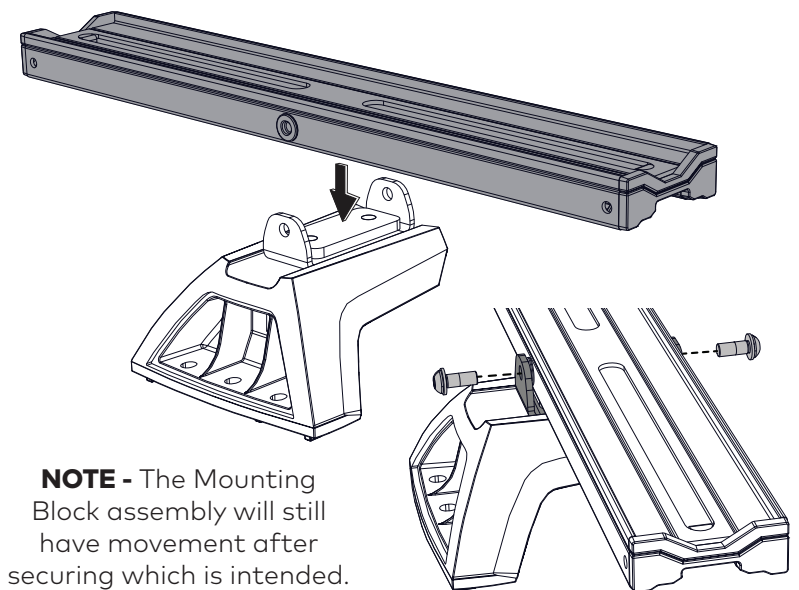

NOTE - The Mounting Block assembly will still have movement after securing which is intended.

**PLEASE PROCEED TO PAGES 11 - 13 FOR
VEHICLE MOUNTING INSTRUCTIONS**

LEG MOUNTING INSTRUCTIONS

1 REMOVE LEG COVERS

Using the keys supplied in the LockNLoad Leg Kit (sold separately), remove all Leg Covers.

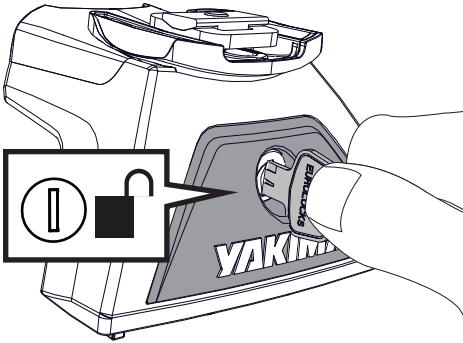

2 DISASSEMBLE LEG ASSEMBLIES

Disassemble Leg components as shown and store in a safe place.

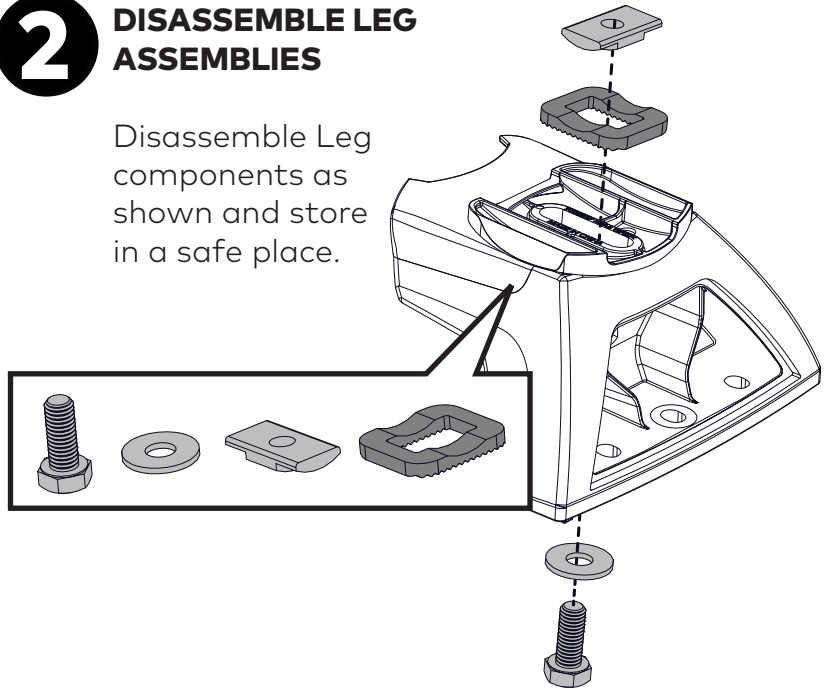

3 ASSEMBLE LEGS

Assemble each Leg as shown using one Platform Mount Bracket, M8 Coach Bolt, M8 Washer and M8 Nut from the LockNLoad Leg Kit.

All Brackets should be parallel with the base of the Leg prior to tightening.

Tighten all M8 nuts to 9 Nm using a 13 mm Spanner.

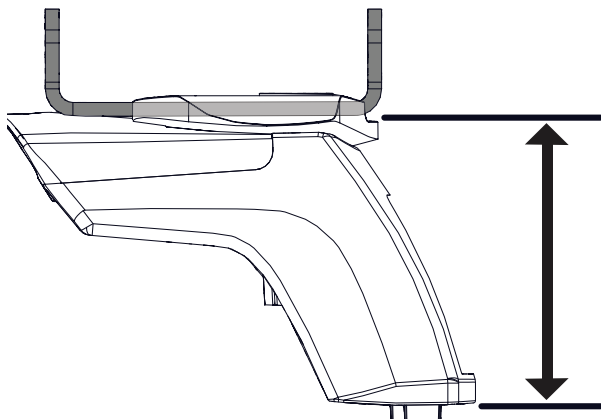
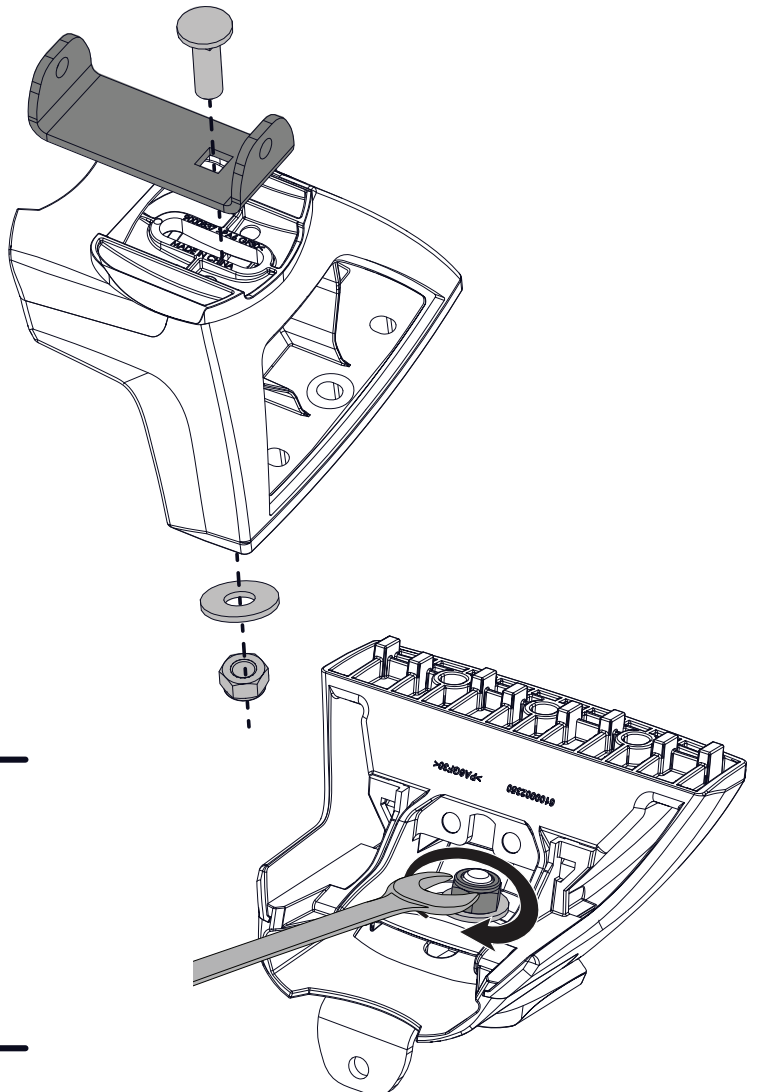

4

INSTALL MOUNTING BLOCKS

Place a Mounting Block (from Platform Kit) on top of each Leg assembly, lining up the rivnut holes on Mounting Block with holes on tabs of Platform Mount Bracket.

Secure with two M6 Capscrews 16 mm with Washers as shown.

Tighten all Capscrews to 4 Nm with a 4 mm Ball End Allen Key or a suitable Torque Wrench.

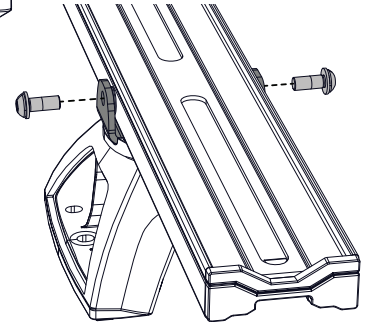
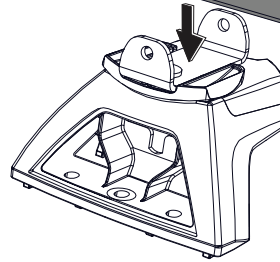
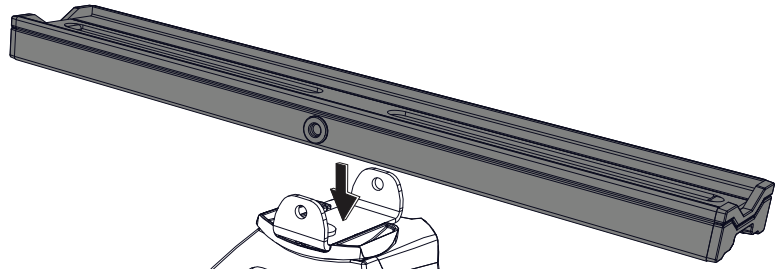

NOTE - The Mounting Block assembly will still have movement after securing which is intended.

PLEASE PROCEED TO PAGES 11 - 13 FOR VEHICLE MOUNTING INSTRUCTIONS

VEHICLE MOUNTING INSTRUCTIONS

1 MOUNT LEGS TO VEHICLE

Mount Legs to vehicle as per LockNLoad vehicle specific Mounting Kit (sold separately). Vehicle specific instructions can be viewed and downloaded at our website.

NOTE - Bars are not required to install Platform.

YAKIMA LockNLoad™ Track Mounting Kit
 MITSUBISHI TRITON MQ DUAL CAB 2015-
 2 BAR TRACK HEAVY DUTY ROOF RACK SYSTEM

MAX VEHICLE ROOF LOAD RATING: 100 KG
 TOTAL LOAD EQUALS WEIGHT OF ROOF RACKS + ACCESSORIES + CARGO

FIRST TIME INSTALLATION

- Please read instructions carefully before installation.
- Check the contents of kit, contact your YAKIMA dealer if any parts appear missing or damaged.
- Check your roof thoroughly prior to fitting the LockNLoad Track Heavy Duty Roof Rack System.
- Please these instructions in the vehicle's glove box after installation is complete.

TOOLS REQUIRED:

- Power or Cordless Drill
- Screws
- 10 mm Open Ended Spanner
- Span Measure
- 12 mm Socket or Spanner
- Masking Tape
- Rubber Mallet (Optional)
- Block Gun
- Flat Head Screw Driver
- Drill Bit Stop
- Mastic Silicone Sealant
- Vehicle Cleaner
- Mastic Silicone Sealant
- #2 Phillips Head Screwdriver
- Zinc Rich Cold Galvanneal Coating

KIT CONTENTS

| ITEM | COMPONENT | QTY | ITEM | COMPONENT | QTY |
|------|------------------------------------------|-----|------|--------------------------|-----|
| 1 | Track Mkt. Triton MQ 15- Right Hand Side | 1 | 1 | 43 mm Drill Bit | 1 |
| 2 | Track Mkt. Triton MQ 15- Left Hand Side | 1 | 10 | LockNLoad Height Puckets | 10 |
| 3 | Track Nut Plate | 1 | 1 | End Cap Rear Left | 1 |
| 4 | Mo Washer | 1 | 1 | End Cap Rear Right | 1 |
| 5 | MS Spring Washer | 1 | 1 | End Cap Front Left | 1 |
| 6 | Wash | 1 | 1 | End Cap Front Right | 1 |
| 7 | MS Hex Screws 20 mm | 1 | 1 | MS Bottom Panel Channels | 2 |
| 8 | MS Hex Screws 30 mm | 1 | 1 | Front Gun Nozzle | 1 |

LED AND BAR COMPONENTS SOLD SEPARATELY

2 LIFT PLATFORM ONTO VEHICLE

With the help of an assistant, carefully lift Platform up and onto Mounting Blocks on vehicle roof. Centre Platform evenly on Legs so there is an equal overhang on sides and ideally on the front and rear.

NOTE - Wind Deflector is to be at the front of the vehicle.

NOTE - For hatch vehicles ensure to position the Platform so that there is adequate hatch clearance when fully opened.

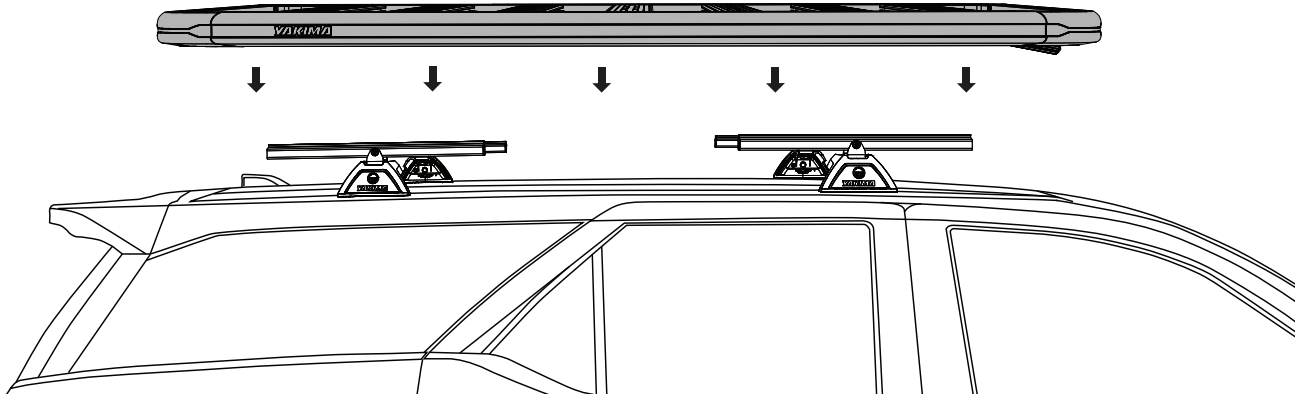

3 MAXIMUM OVERHANG

The maximum unsupported distance from Mounting Block is ONE slat on either end as shown.

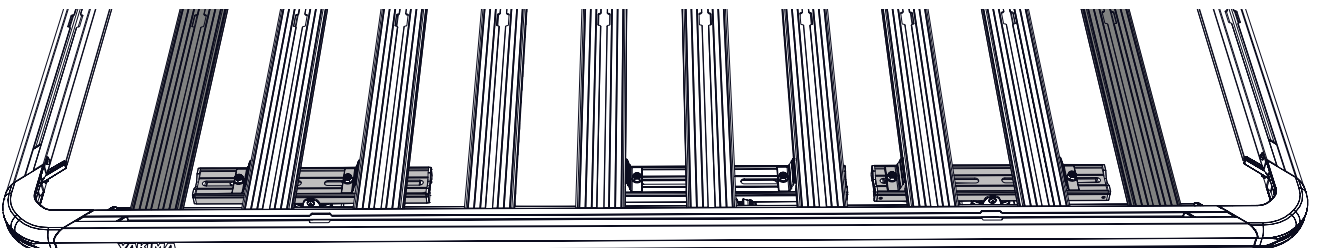

4 INSERT T-BOLTS INTO MOUNTING BLOCKS

Insert one M8 T-Bolt into Mounting Block channel on either side of each Leg. Twist to lock into place. The larger the distance between each pair of M8 T-Bolts the better. See images for possible location scenarios:

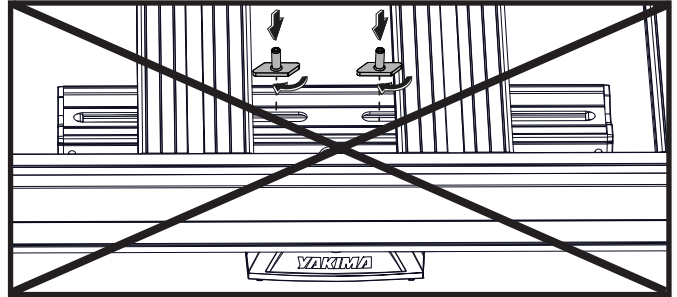

Do not use this configuration

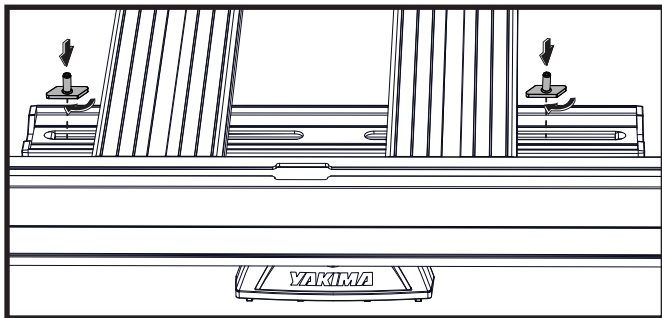
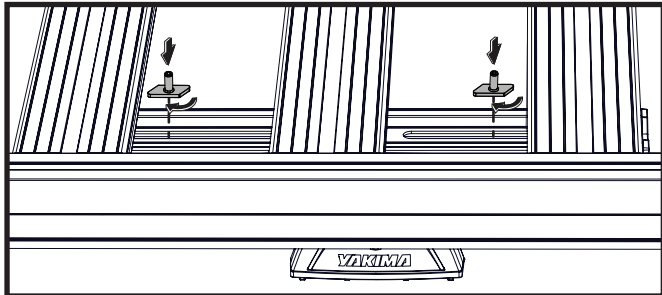

4a PLATFORM F ONLY (1570 x 805 mm)

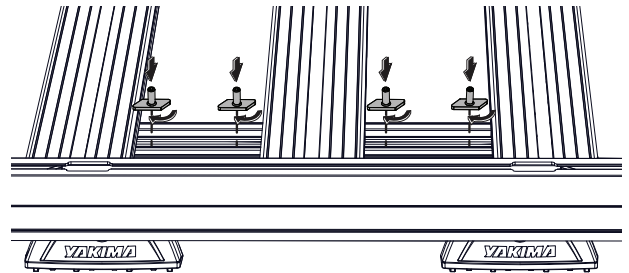

5 SECURE MOUNTING BLOCKS

Secure Mounting Blocks to Platform Slats using one Slat Clamp, one M8 Washer and one M8 Nyloc Nut onto each M8 T-Bolt as shown.

Tighten all Nuts to 7 Nm using a 13 mm Socket Wrench or Spanner.

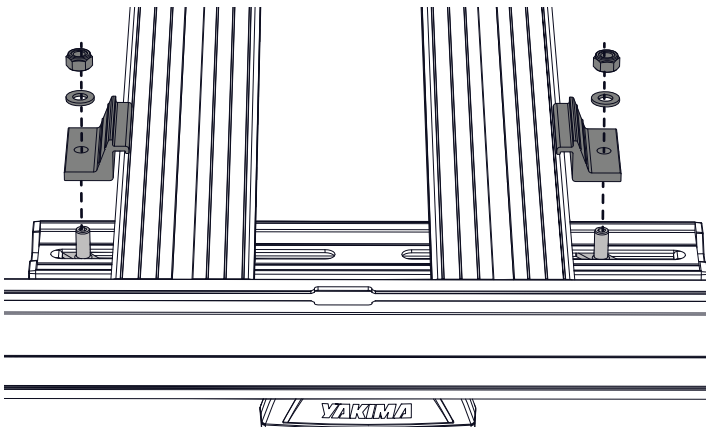

5a PLATFORM F ONLY (1570 x 805 mm)

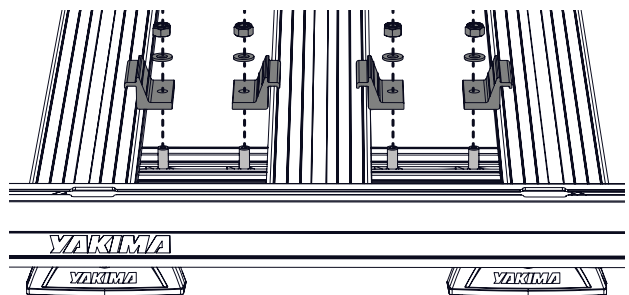

NOTE - Do not over tighten Slat Clamps past 7 Nm as this may reduce clamping force.

6**PLATFORM MOUNTING COMPLETE**

Check that Platform has been secured correctly as per the mounting instructions.

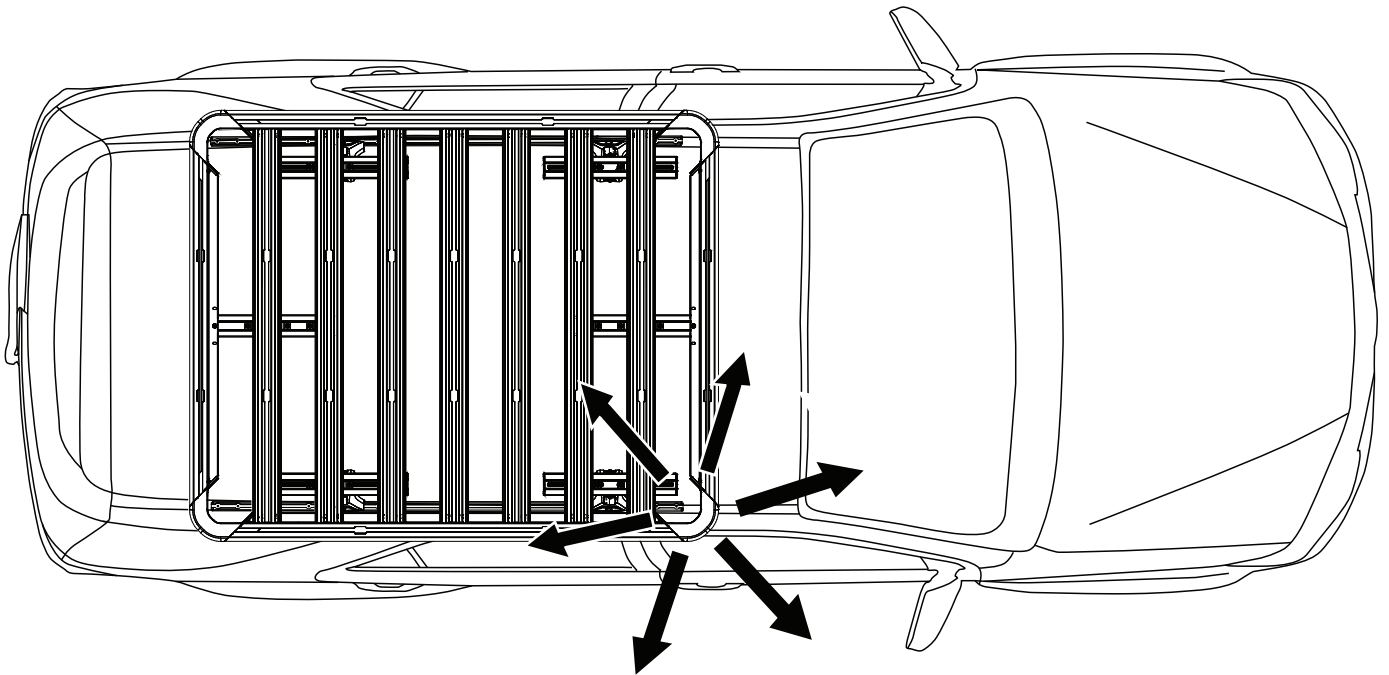

NOTE - 7 Slat Platform shown - indicative sizes A and B.

**WIND DEFLECTOR
REMOVAL**

NOTE - The Wind Deflector can be removed to suit certain anchors/accessories to be used with the front extrusion. This is done by simply peeling the part out of the slot, starting at one end and working across the length of the deflector.

Installation is the reverse and should be confirmed by hearing an audible 'CLICK' when the deflector is fully installed.

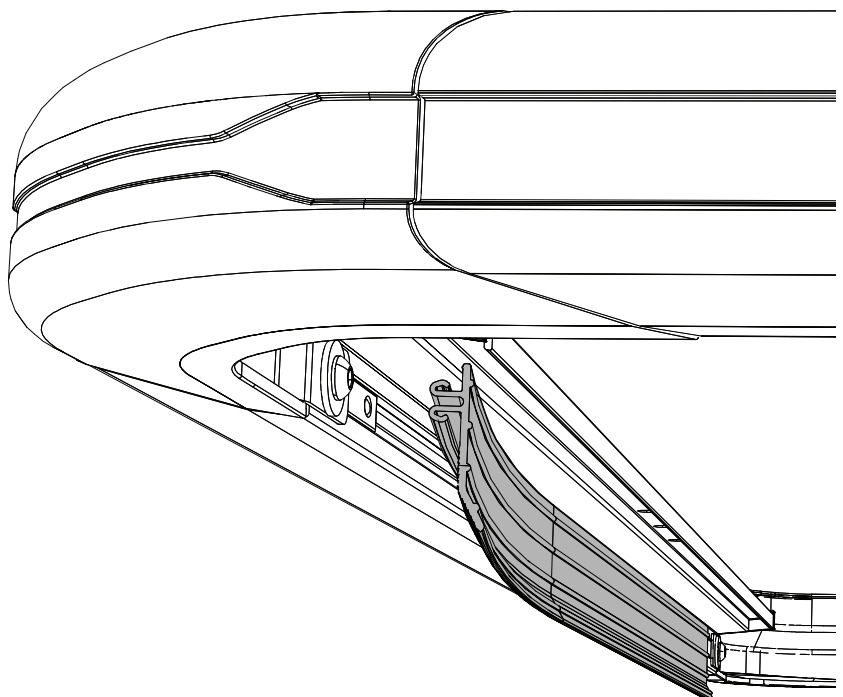



www.yakima.com.au
www.yakima.com

YAKIMA AUSTRALIA PTY. LTD

17 Hinkler Court
Brendale, QLD 4500
Australia
1800 143 548

YAKIMA PRODUCTS, INC.

4101 Kruse Way
Lake Oswego, OR
97035-2541
USA
888 925 4621