

**YAKIMA**

# FrontLoader

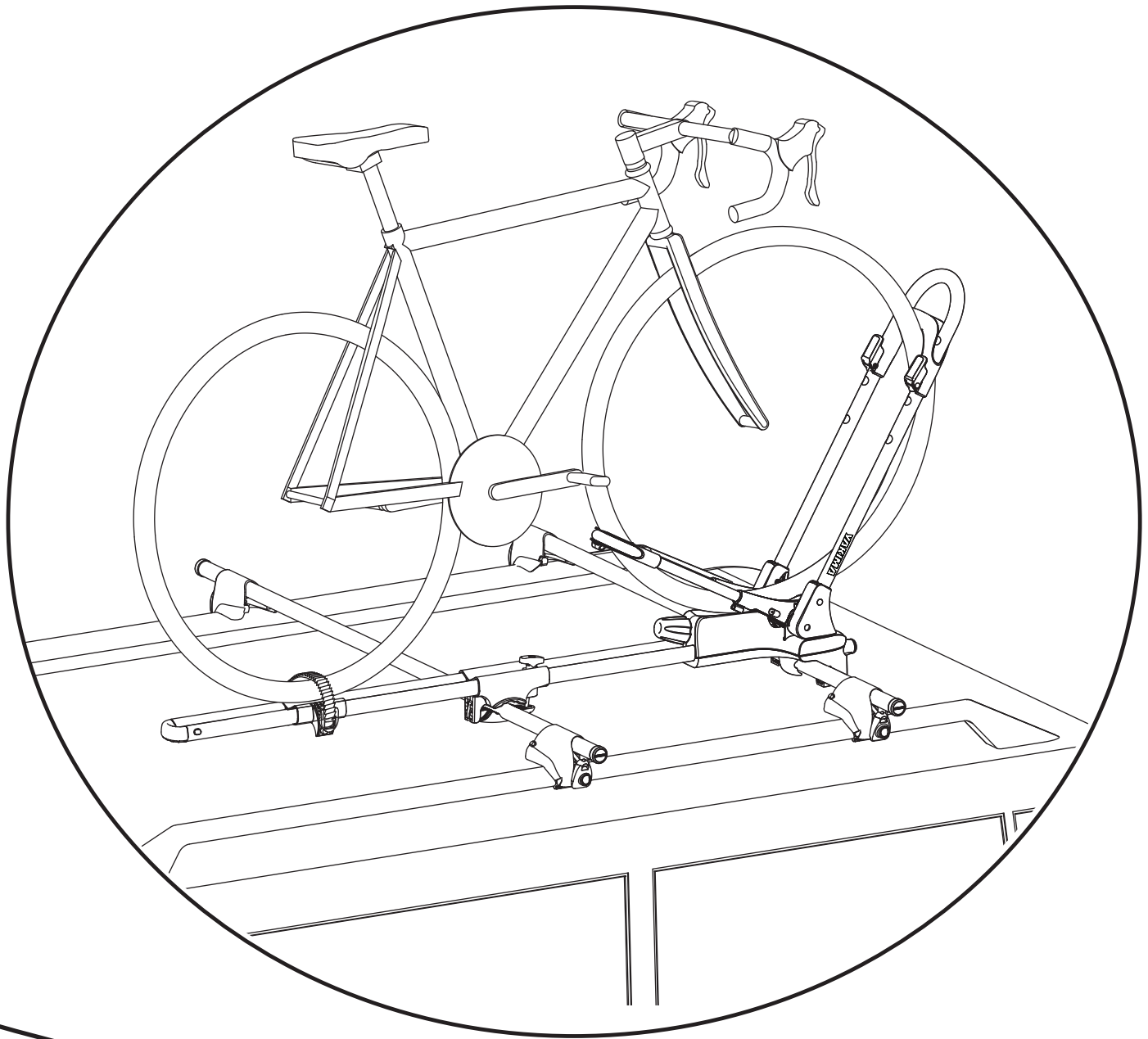

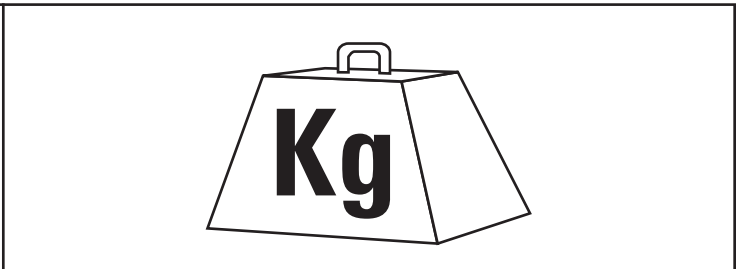
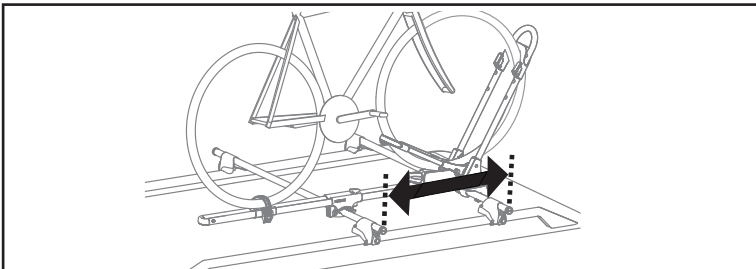
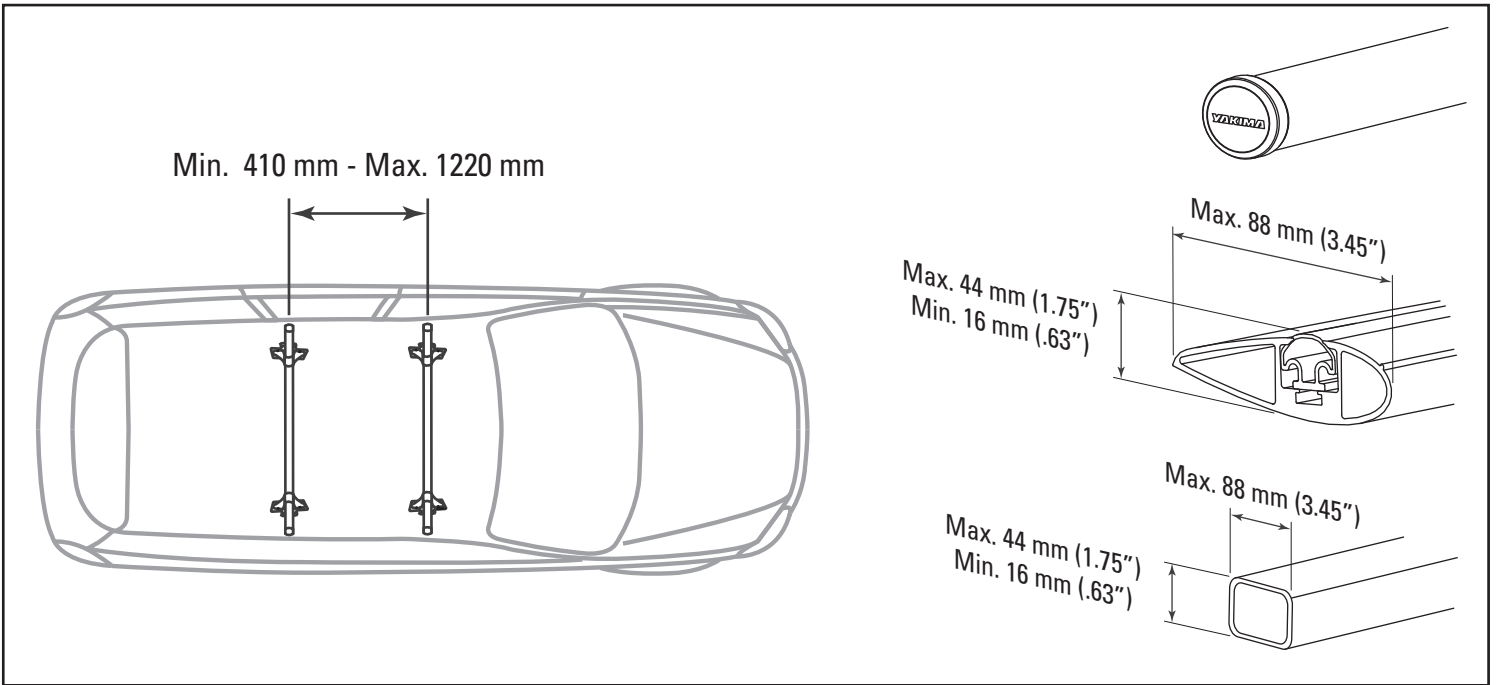
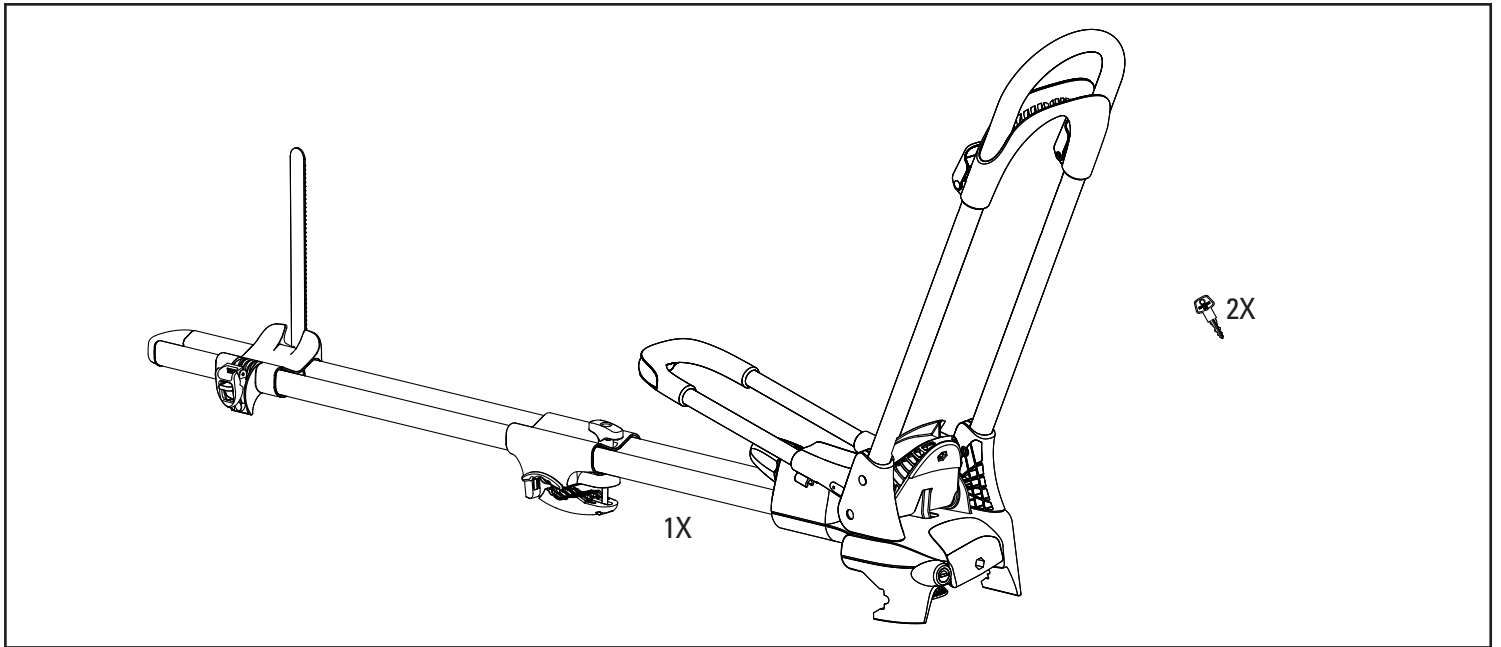

- GB Fitting instructions
- DE Montageanleitung
- FR Notice de montage
- ES Instrucciones de montaje
- IT Istruzioni per il montaggio

Part #1033635 Rev.B



410mm - 460mm

13.6Kg /   
2x  MAX.

460mm - 1220mm

18.1Kg / 

# INSTALLATION • MONTAGE • INSTALLATION • INSTALACIÓN • MONTAGGIO

1

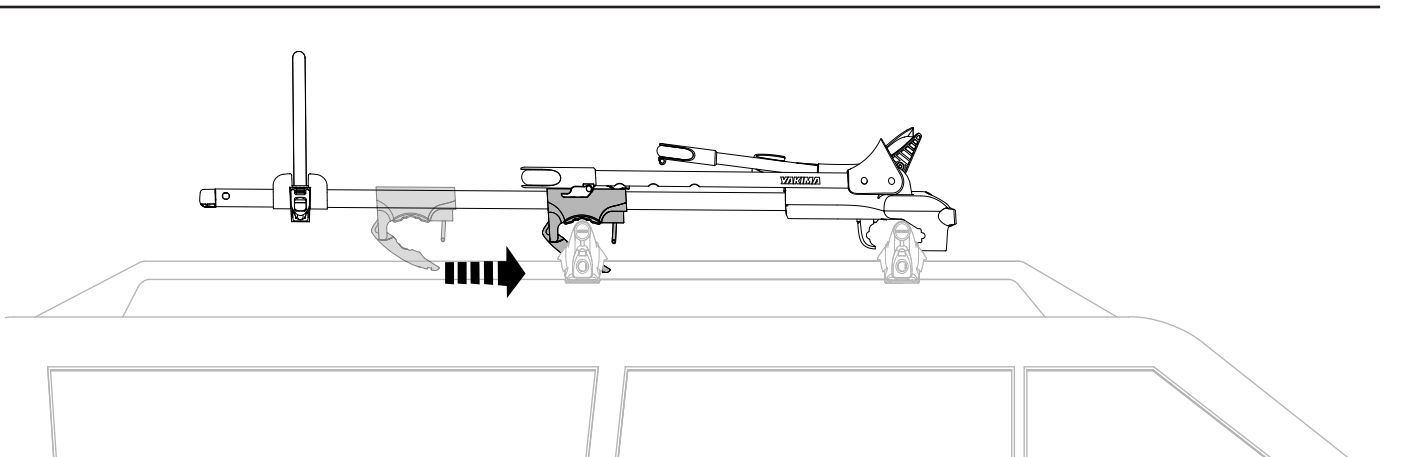
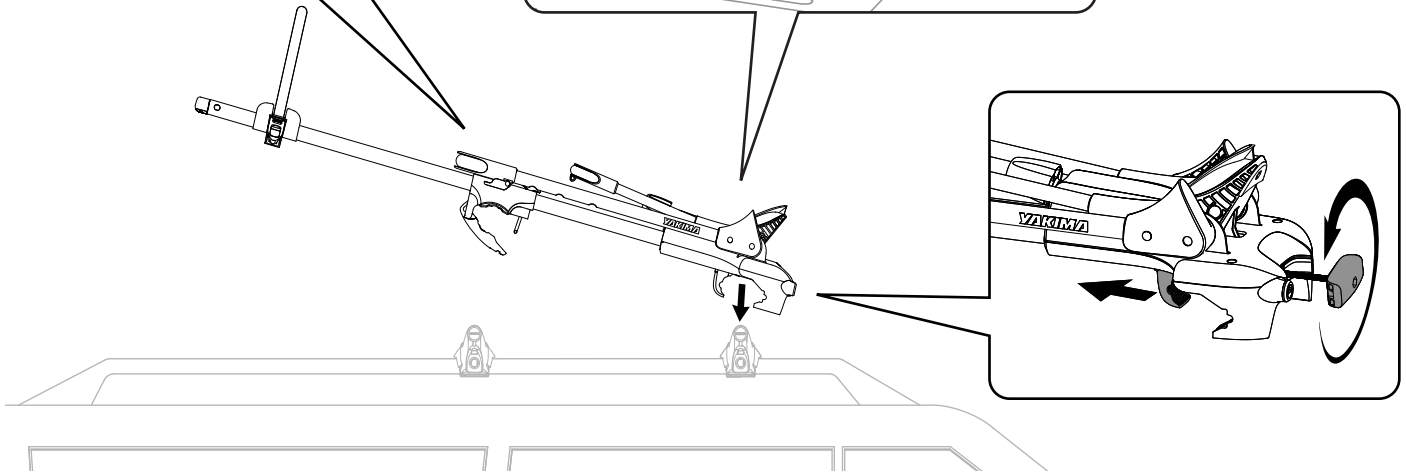
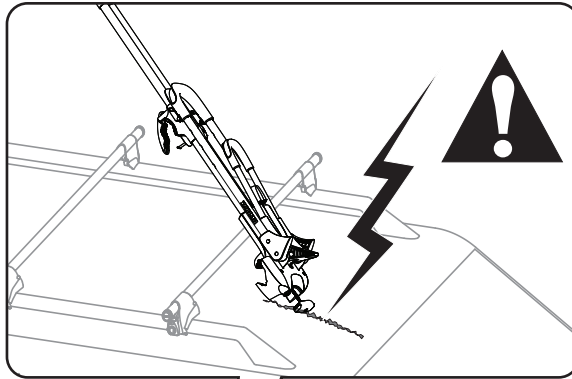
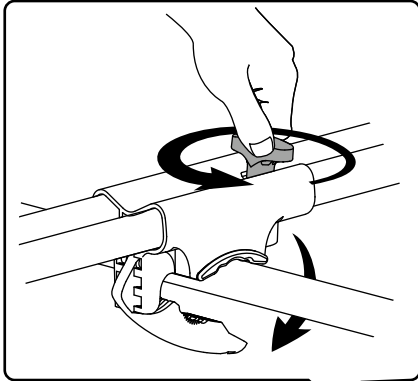
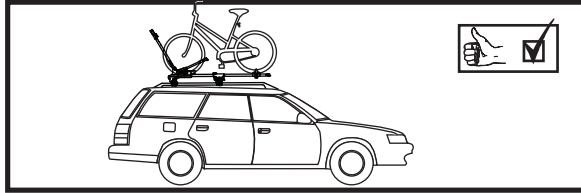
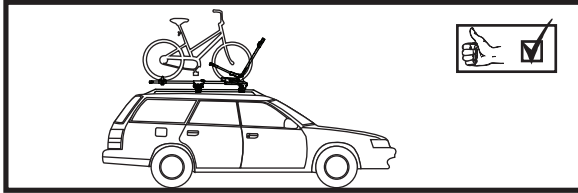

**2**

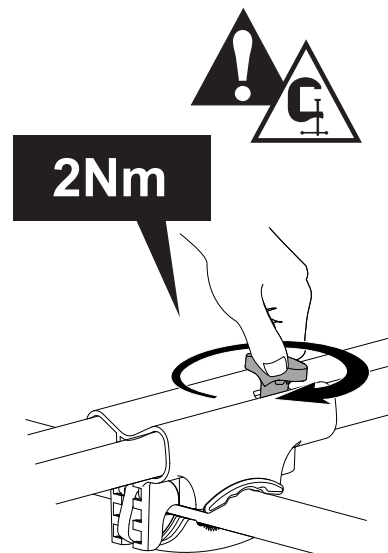
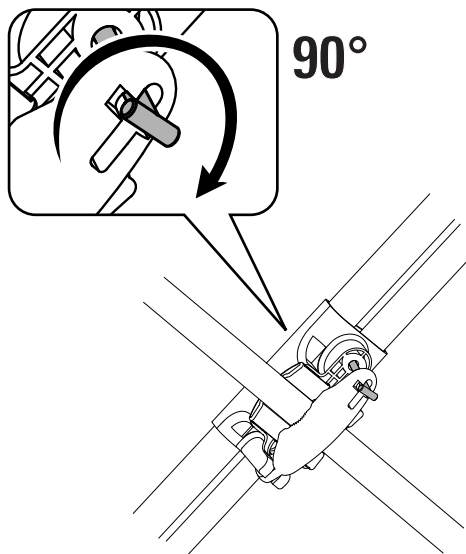
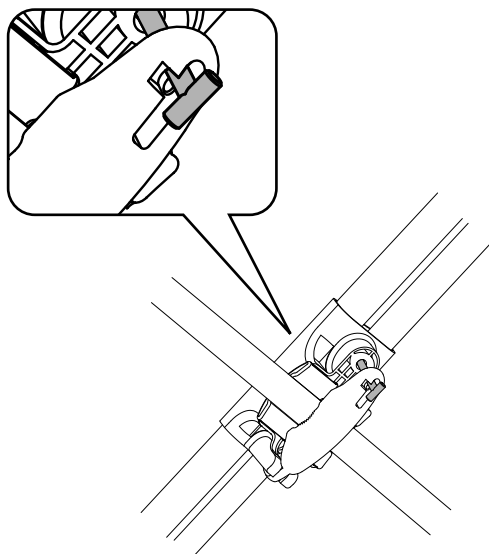
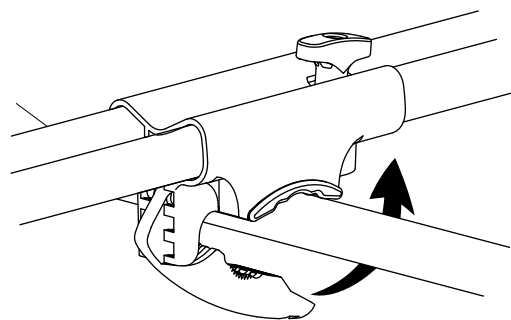
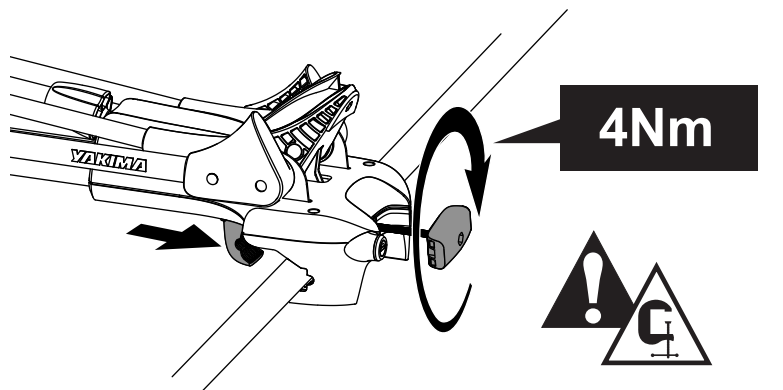
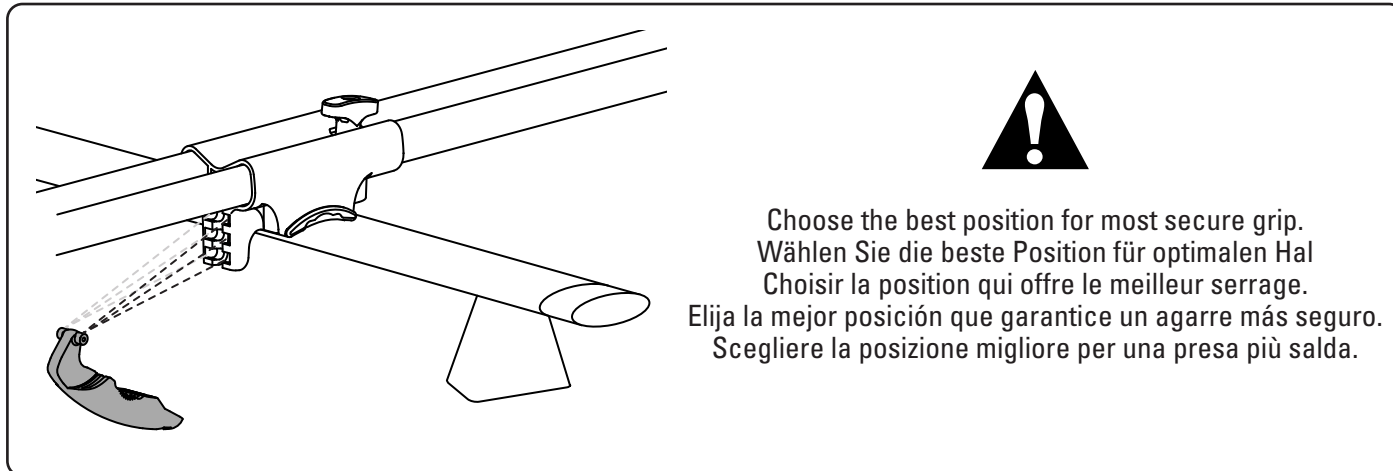
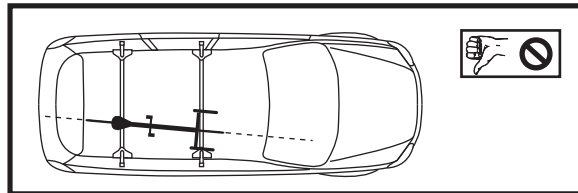
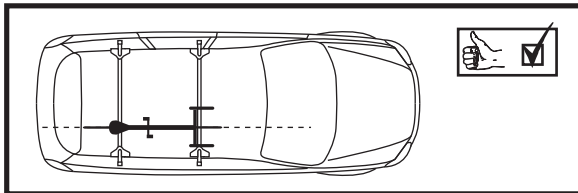

**OPTIONAL  
SONDERZUBEHÖR  
FACULTATIF  
OPCIONAL  
OPZIONALE**

Orient buckle for easiest access when loading or unloading.

Richten Sie die Schnalle so aus, dass sie beim Be- und Entladen leicht erreichbar ist.

Mettre la boucle dans le sens qui facilitera l'accès lors du chargement et du déchargement.

Coloque la hebilla del lado que resulte más fácil cargar o descargar la bicicleta.

Orientare l'aggancio in modo da facilitare l'accesso per carico e scarico.

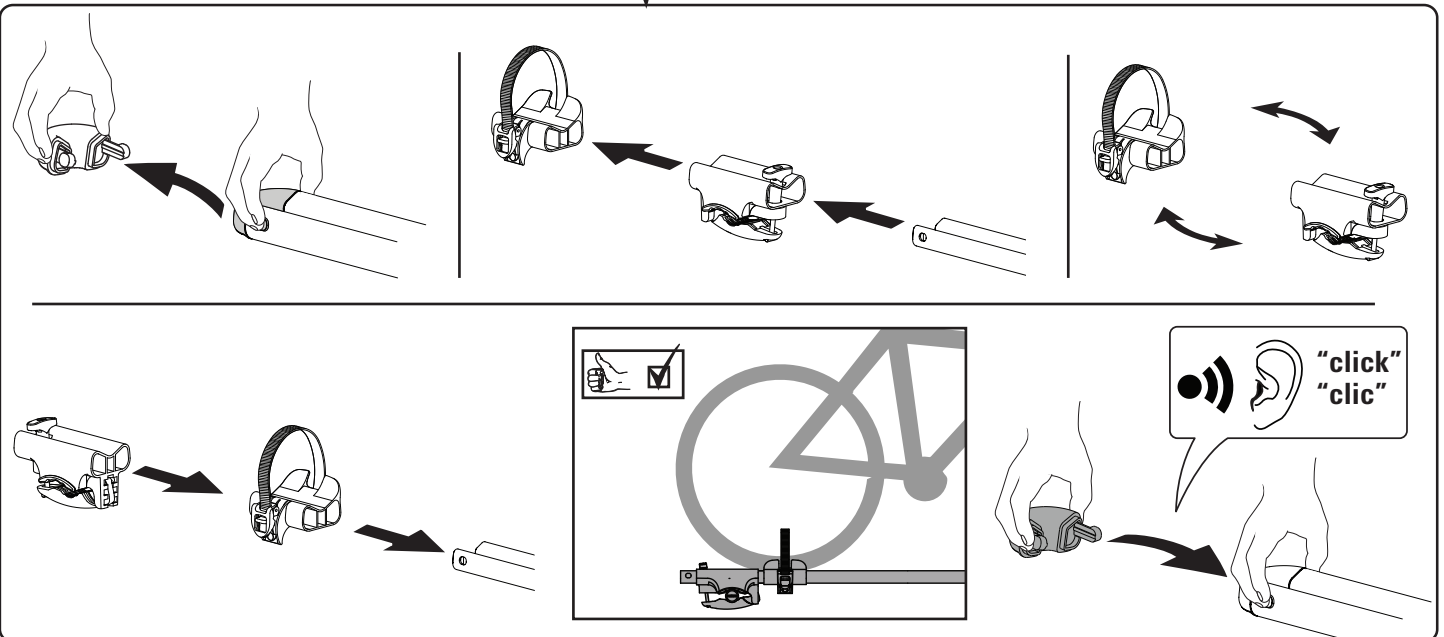
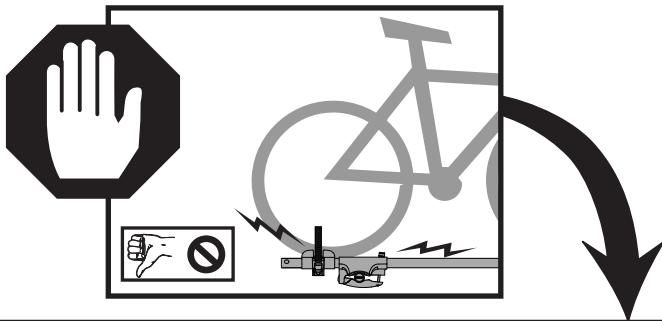
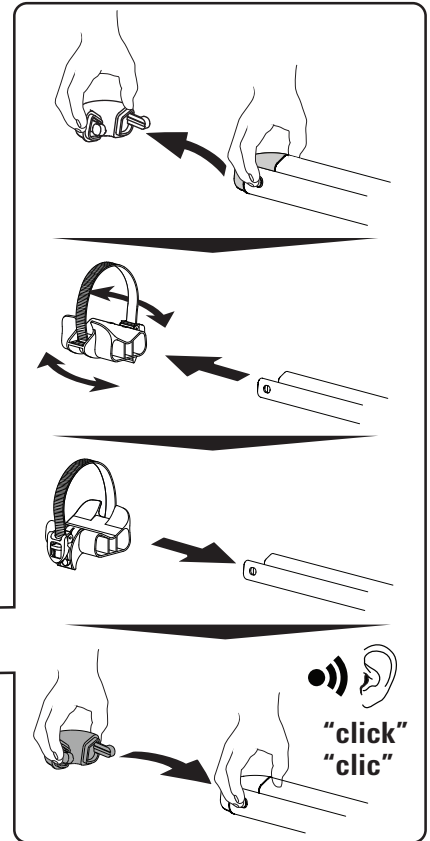
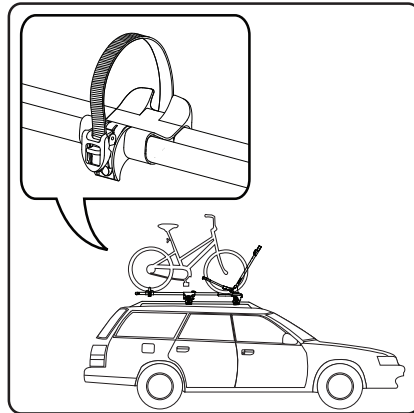
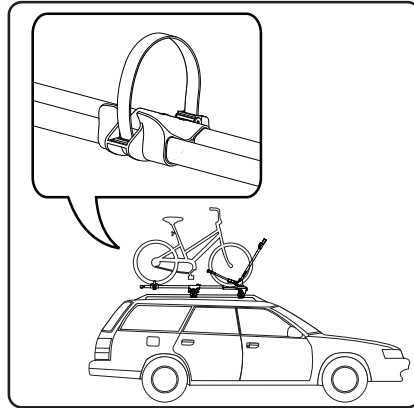

3

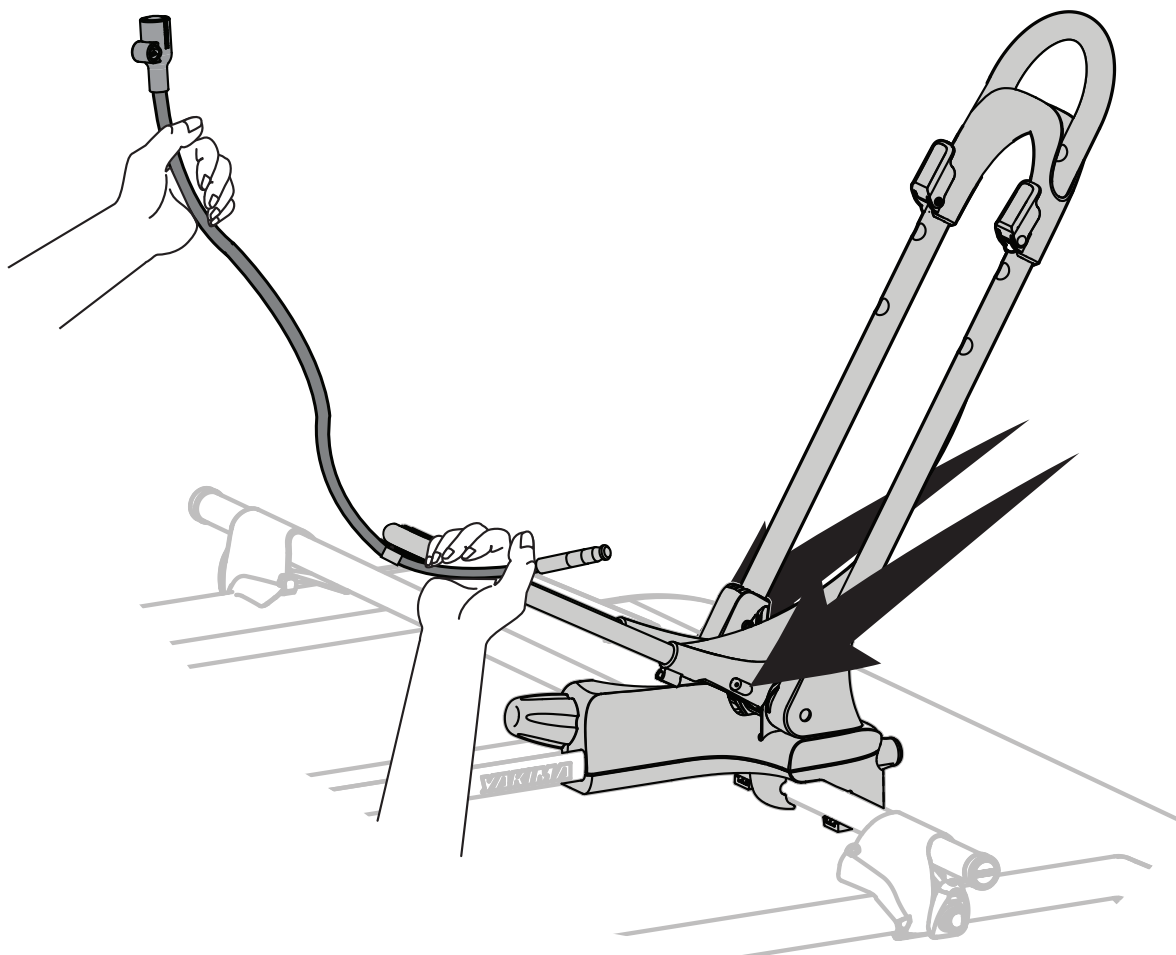

**Lock cable storage.**  
**Verschließen Sie das Kabelfach.**  
**Rangement du câble de verrouillage.**  
**Almacenaje del cable con cerradura**  
**Scomparto cavo antifurto.**

NOTE: Front knob must be in horizontal position to lock.  
ANMERKUNG: Zur Verriegelung muss sich die vordere Schraube sich in waagerechter Position befinden.  
REMARQUE : le bouton avant doit être à l'horizontale pour pouvoir le verrouiller.  
NOTA: La perilla delantera debe estar en la posición horizontal para que trabé.  
NOTA BENE: Per bloccarsi, la manopola anteriore dev'essere in posizione orizzontale.

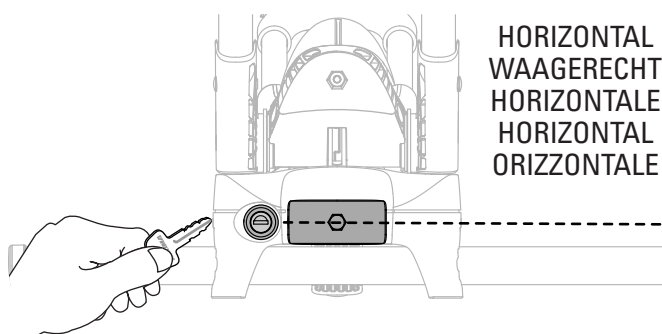

# LOADING • BELADEN • CHARGEMENT • CARGA • CARICO

## 4

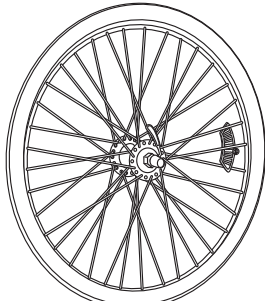

29x 1.8-2.3"  
700x 41-55mm

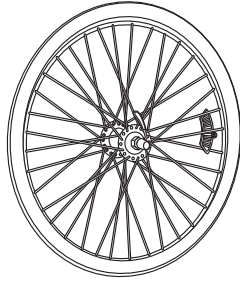

26x2.0-2.5"  
700x20-40mm

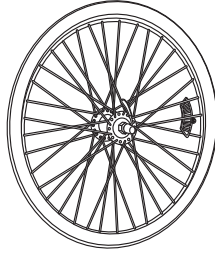

26x1.0-1.95"  
650x20-28mm

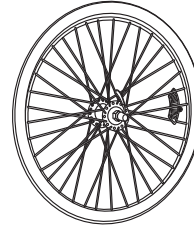

24"

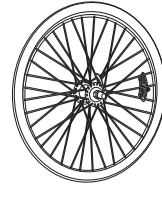

20"

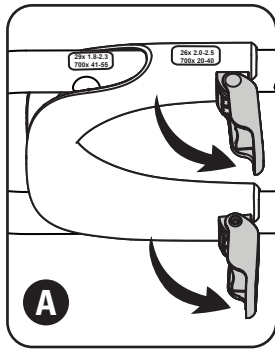

A

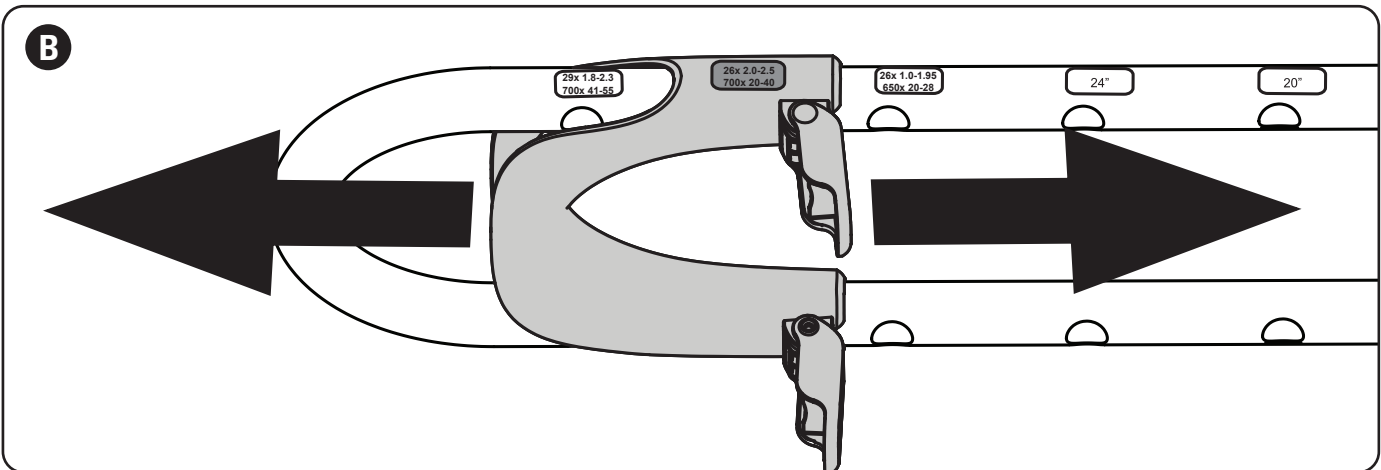
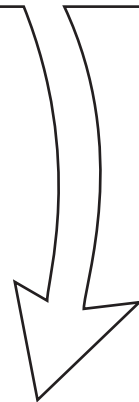

B

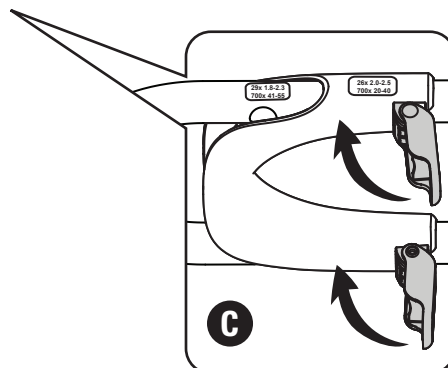

C



"click"  
"clac"

5

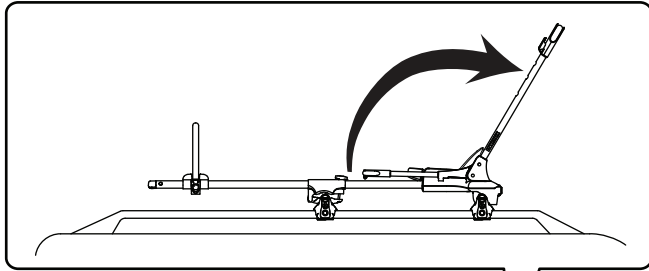

Tire must be fully inflated.  
 Der Reifen muss vollständig aufgepumpt sein  
 Le pneu doit être correctement gonflé.  
 El neumático debe estar completamente inflado.  
 I pneumatici devono essere ben gonfi.

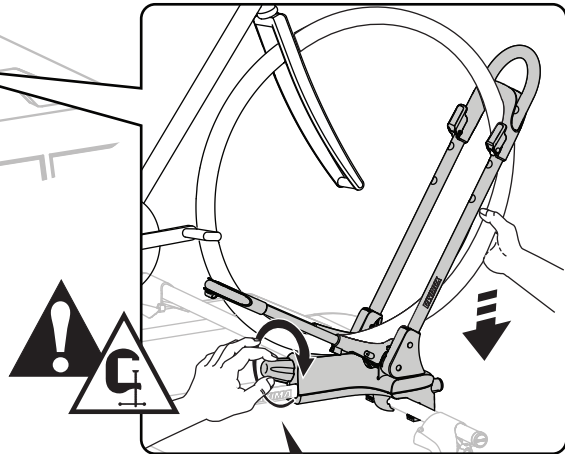
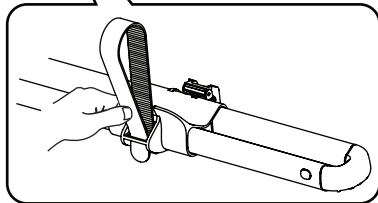
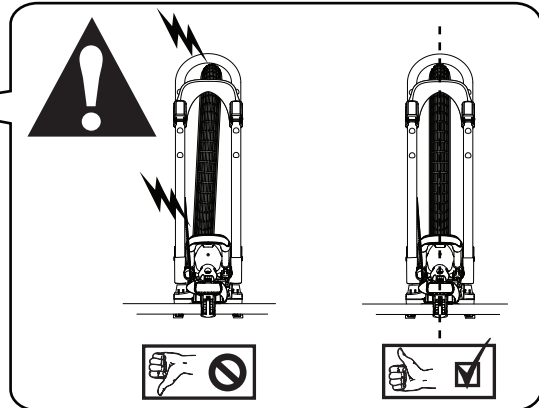
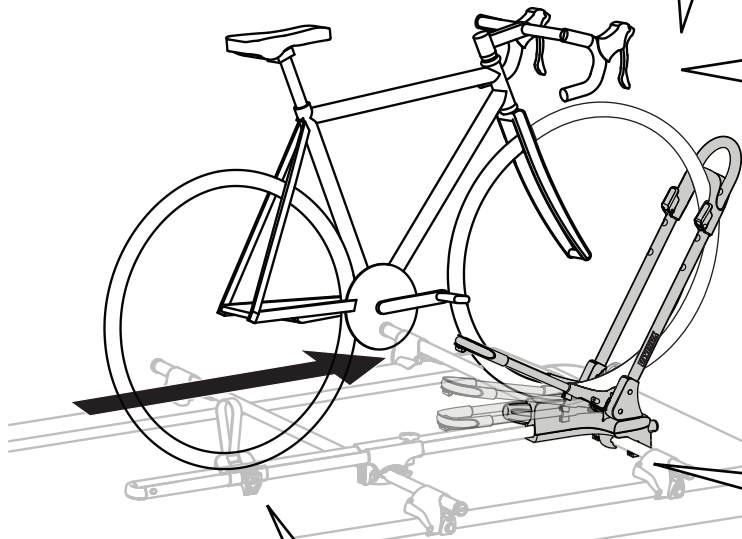

3Nm

6

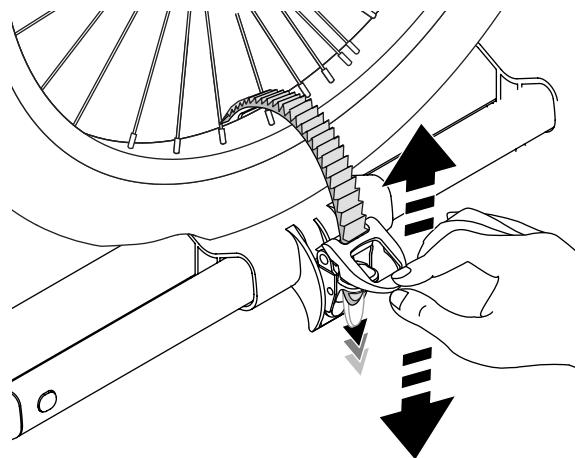
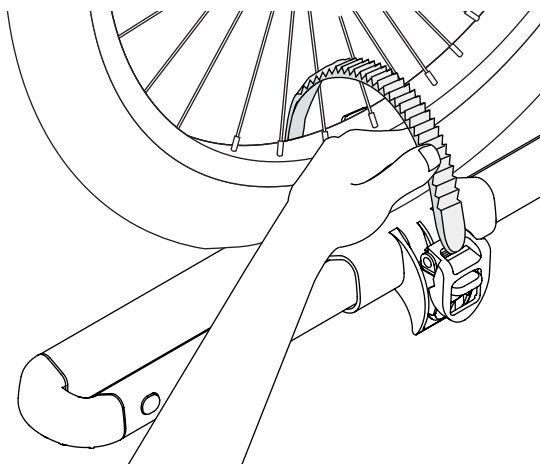



7

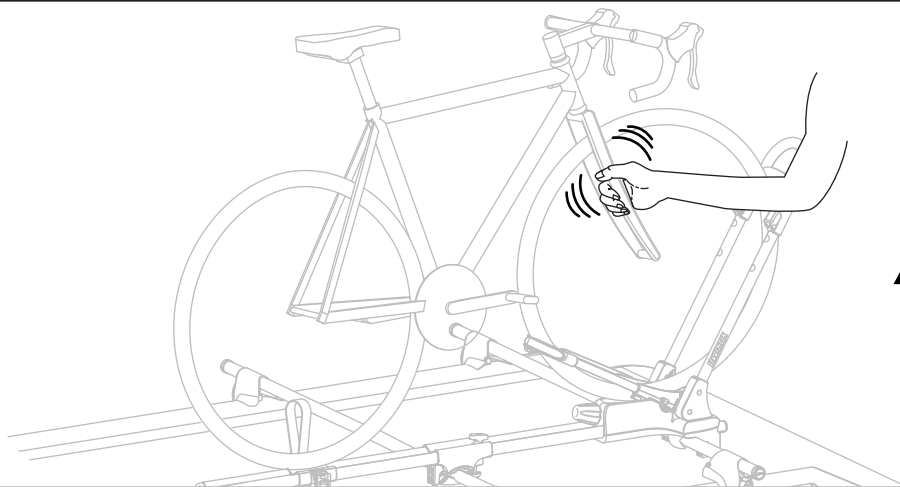

8

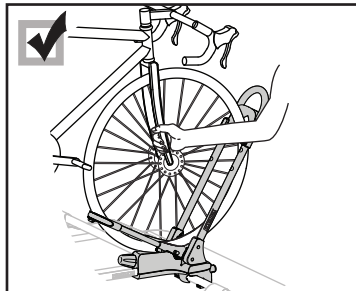
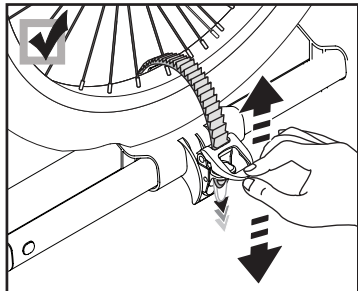
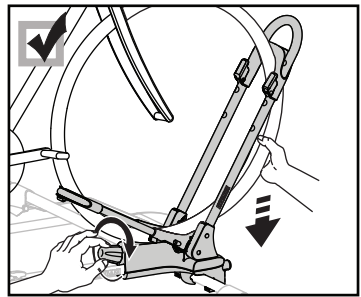
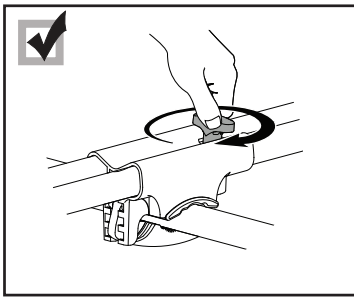
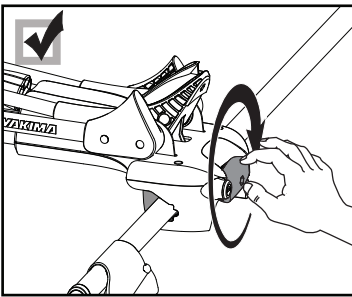
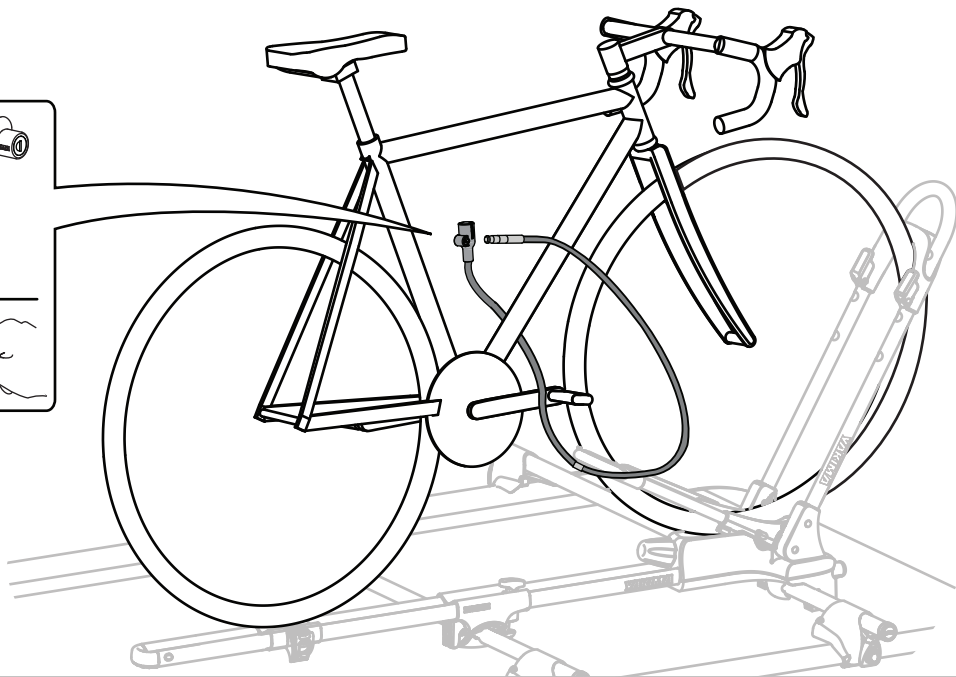
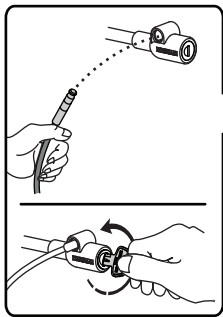

**UNLOADING • ABLADEN • DÉCHARGEMENT • DESCARGA • SCARICO**

**9**

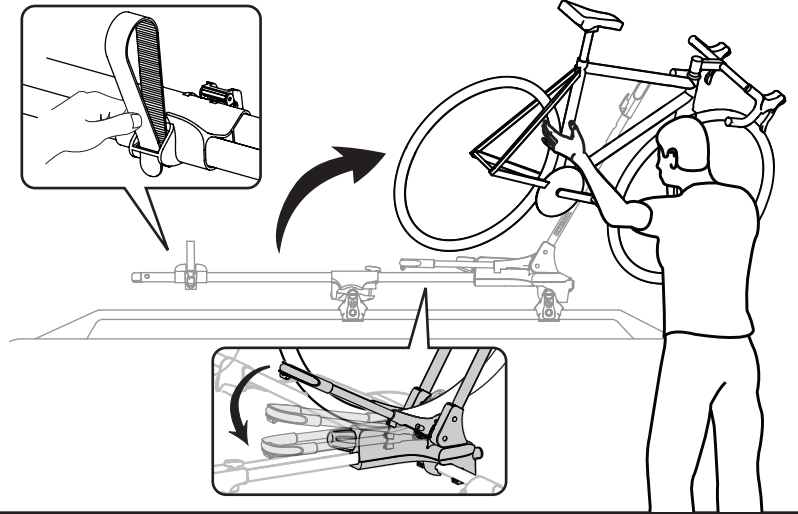
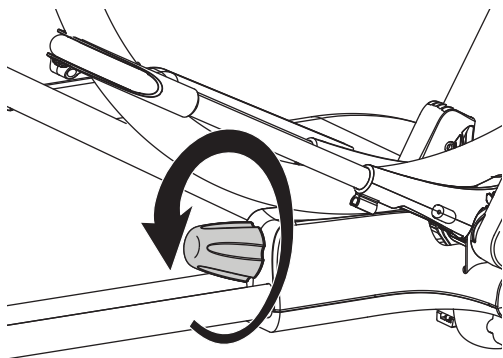
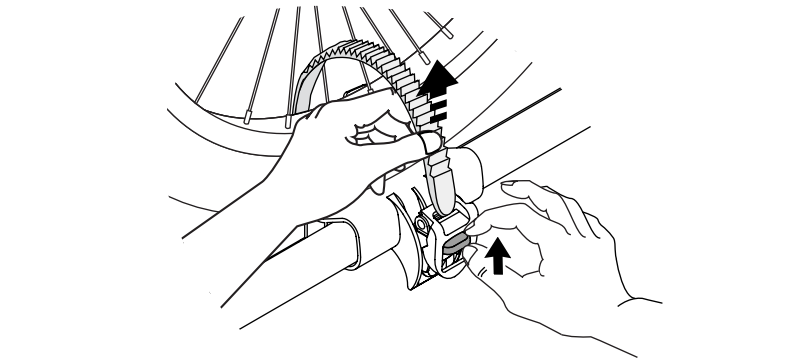
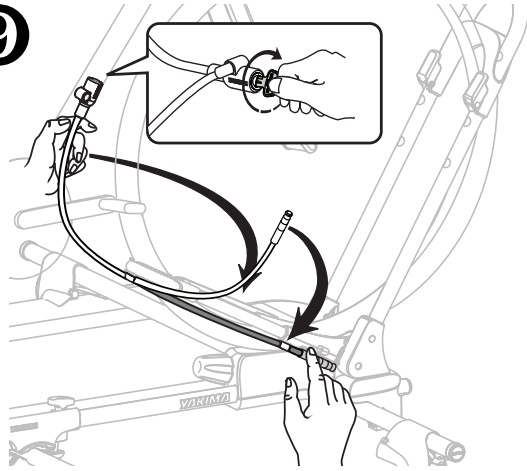

**REMOVAL • ABMONTIEREN • DÉPOSE • DESMONTAJE • SMONTAGGIO**

**10**

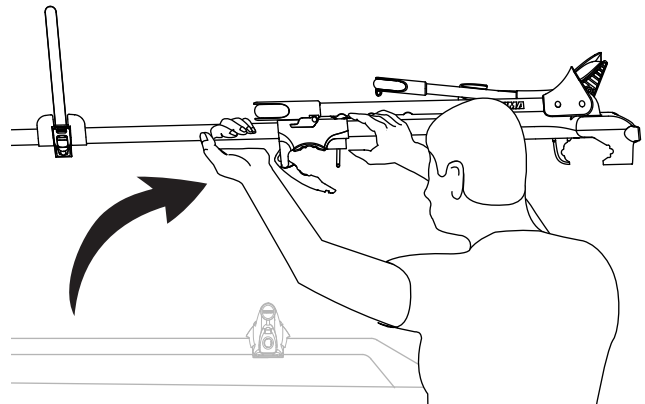
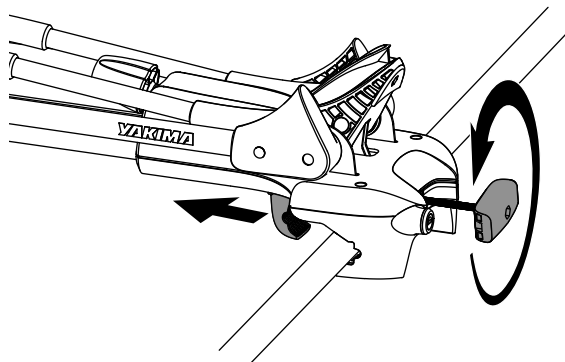
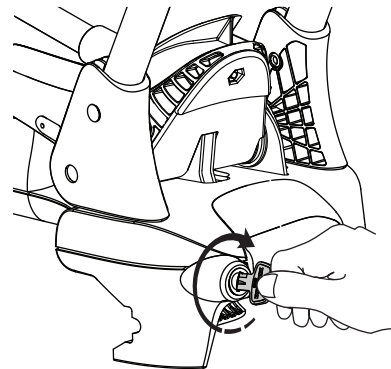
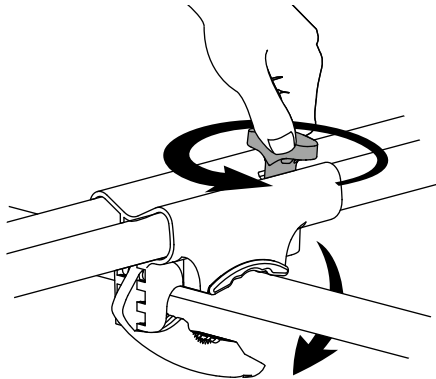

**GB** Accessories  
**ES** Accesorios

**DE** Zubehör  
**IT** Accessori

**FR** Accessoires

**#8007202**

SKS Lock Cores 2 Pack  
SKS Zylinderkern Doppelpack  
Paquet de 2 serrures SKS  
Juego de 2 cerraduras SKS Lock Cores  
Confezione da 2 cilindri serrature SKS

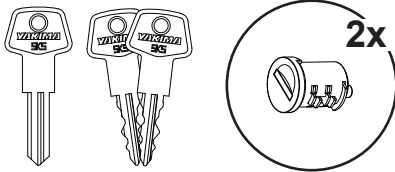

**#8007204**

SKS Lock Cores 4 Pack  
SKS Zylinderkern Viererpack  
Paquet de 4 serrures SKS  
Juego de 4 cerraduras SKS Lock Cores  
Confezione da 4 cilindri serrature SKS

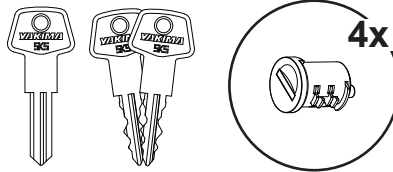

**#8007206**

SKS Lock Cores 6 Pack  
SKS Zylinderkern Sechserpack  
Paquet de 6 serrures SKS  
Juego de 6 cerraduras SKS Lock Cores  
Confezione da 6 cilindri serrature SKS

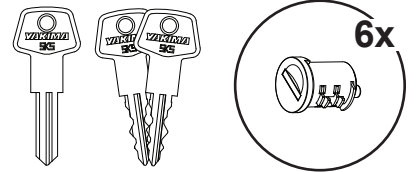

**#8007208**

SKS Lock Cores 8 Pack  
SKS Zylinderkern Zehnerpack  
Paquet de 8 serrures SKS  
Juego de 8 cerraduras SKS Lock Cores  
Confezione da 8 cilindri serrature SKS

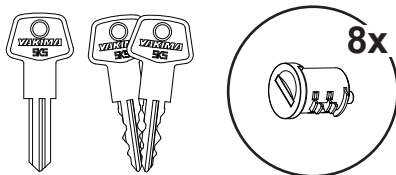

**#8007210**

SKS Lock Cores 10 Pack  
SKS Zylinderkern Achterpack  
Paquet de 10 serrures SKS  
Juego de 10 cerraduras SKS Lock Cores  
Confezione da 10 cilindri serrature SKS

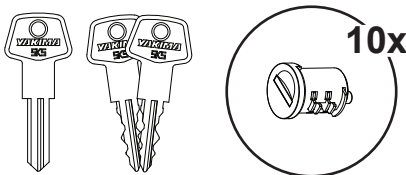

**YAKIMA**

[www.yakima.com.au](http://www.yakima.com.au)  
[www.yakima.co.nz](http://www.yakima.co.nz)  
[www.yakima.com](http://www.yakima.com)  
[www.yakima.eu](http://www.yakima.eu)

**YAKIMA AUSTRALIA PTY LTD**

17 Hinkler Court  
Brendale, QLD 4500  
Australia  
1800 143 548

**YAKIMA PRODUCTS, INC.**

4101 Kruse Way  
Lake Oswego, OR  
97035-2541  
USA  
888 925 4621