

**MAXIMUM PRODUCT LOAD RATING:**

50 kg (size F)

100 kg (sizes A, B, G, I, K, L, S &amp; X)

150 kg (sizes C, D, E, H, N, P &amp; U)

**IMPORTANT:**

- **LOAD = WEIGHT OF PLATFORM or BARS + MOUNTING SYSTEM + ACCESSORIES + CARGO**
- **PLEASE REFER TO VEHICLE MANUFACTURER SPECIFICATIONS FOR MAX ROOF LOAD CAPACITY OF VEHICLE. THE LOWEST LOAD RATING APPLIES.**
- **OFFROAD RATING: SCAN QR CODE FOR LOCKNLOAD LOAD RATING GUIDE. REDUCTIONS MAY APPLY.**

**FIRST TIME INSTALLATION**

- Please read instructions carefully before installation.
- Check the contents of kit. Contact your YAKIMA dealer if any parts appear missing or damaged.
- Clean your vehicle roof prior to fitting the LockNLoad Platform.
- Images throughout show a 7 Slat Platform, indicative of Platform sizes A and B.
- Please note other Platforms will have differing amounts of slats and hardware.
- Place these instructions in the vehicle's glove box after installation is complete.

**TOOLS REQUIRED:**

- Torque Wrench
- 10 mm and 13 mm Socket Wrench or Spanner

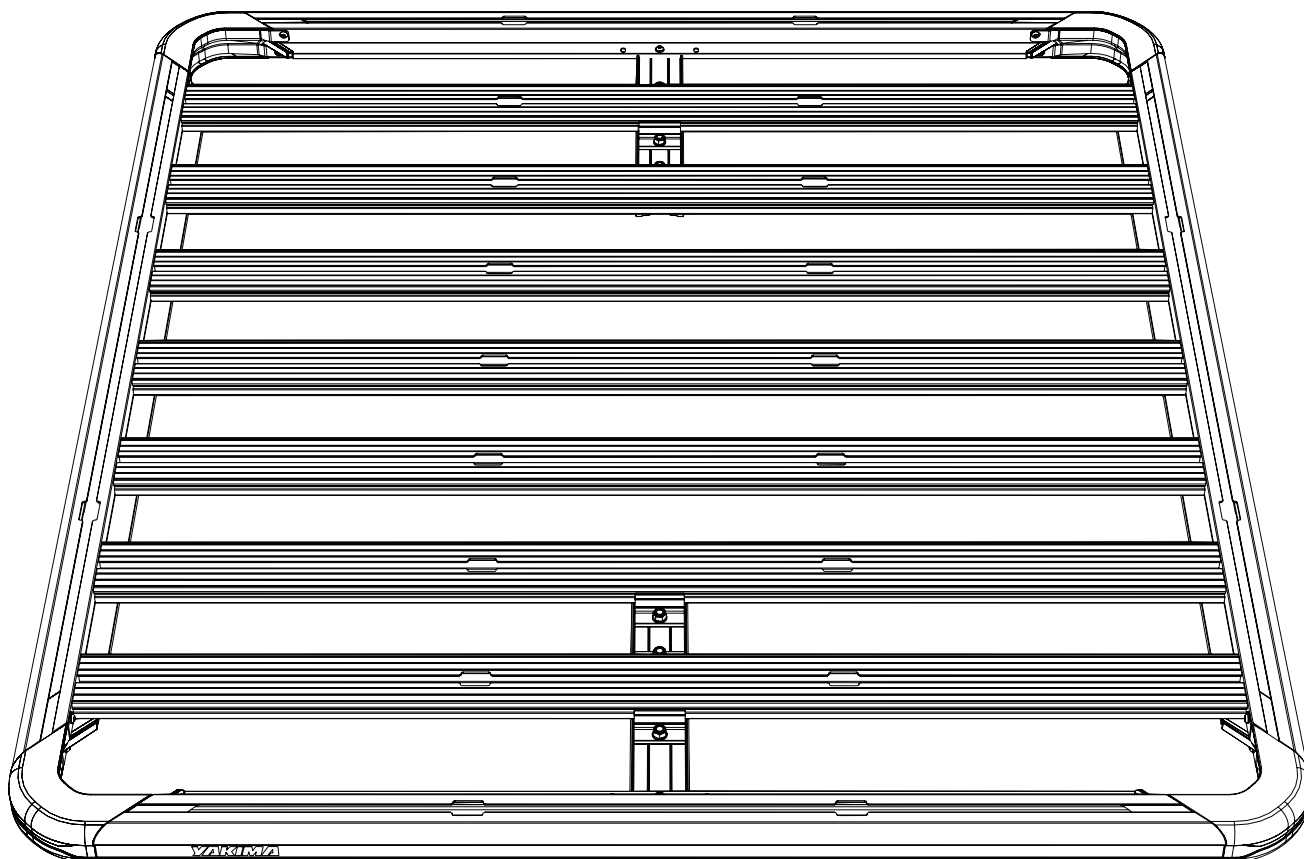

## KIT CONTENTS

ITEM	COMPONENT	QTY
1.	Pre-Assembled Platform	x1
2.	Wind Deflector	x1
3.	Pivot Mount Kit	x1
4.	Spare Fasteners Pack	x1

Platform A - 9820337  
 Platform B - 9820338  
 Platform C - 9820339  
 Platform D - 9820340  
 Platform E - 9820341  
 Platform F - 9820342  
 Platform G - 9820343

Platform H - 9820344  
 Platform I - 9820345  
 Platform K - 9820347  
 Platform L - 9820348  
 Platform N - 9820373

Platform P - 9820375  
 Platform S - 9820378  
 Platform U - 9820380  
 Platform X - 9820383

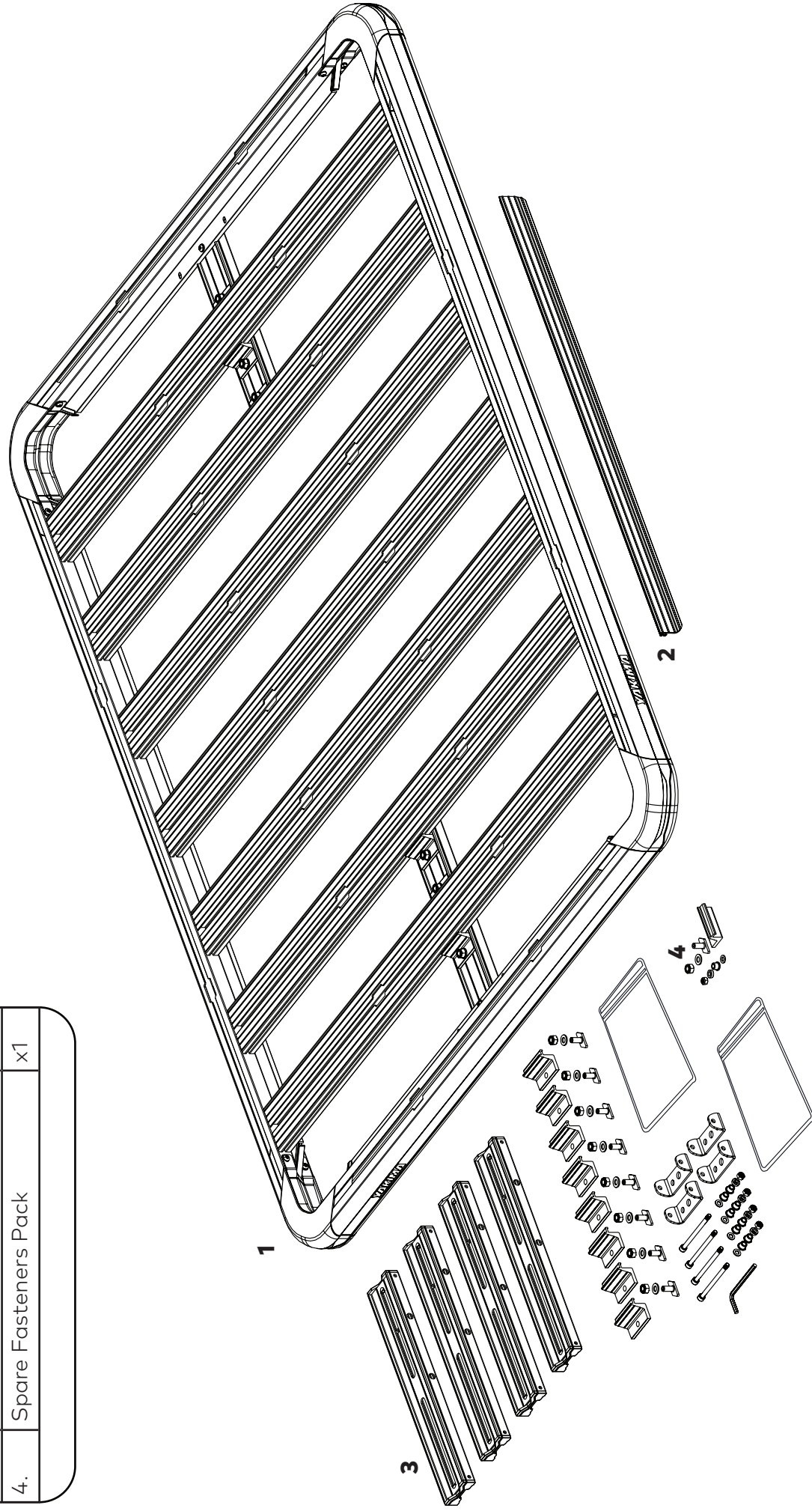

**NOTE** - 7 Slat Platform shown, indicative of Platform sizes A and B.

# 1 REMOVE ASSEMBLED PLATFORM FROM CARTON.

**NOTE** - 7 slat platform shown - indicative of sizes A and B.

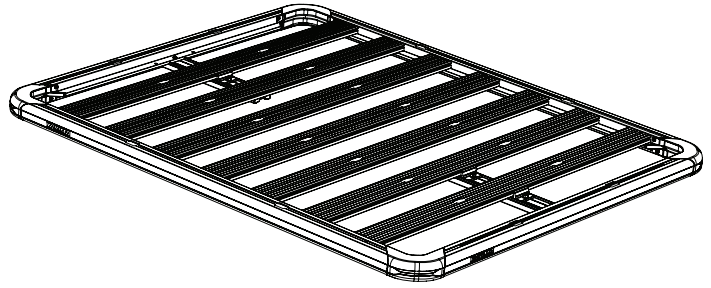



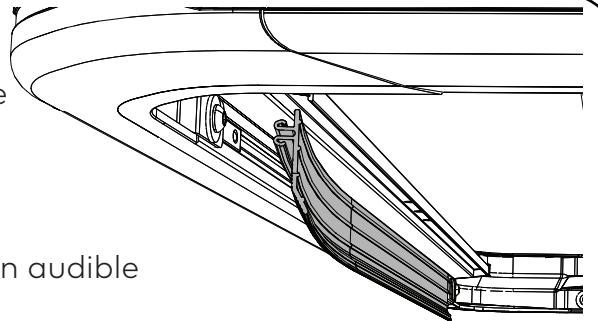

# 2 INSTALL WIND DEFLECTOR.

Install the wind deflector into the front of the platform. This is done by pressing one end of the wind deflector into the slot and working across the length of the deflector.

Installation should be confirmed by hearing an audible 'CLICK' when the deflector is fully installed.

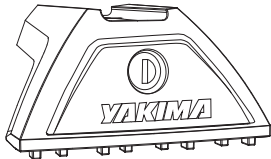
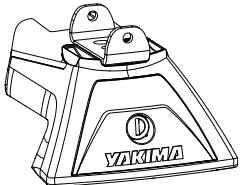

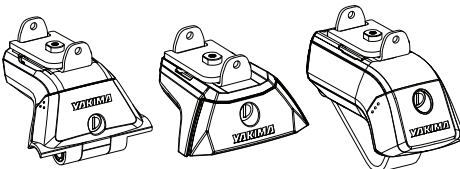
**PLEASE REFER (i) TO THE SPECIAL NOTE AT TOP OF PAGE 4, AND; (ii) TO THE RELEVANT PAGE NUMBERS AND STEPS INDICATED IN THE TABLE BELOW:**

NAME	IMAGE	LEG PACK PART NUMBERS	PAGE	STEPS
Fixed & Track Mount Mk1		8000142 / 8000143 / 8000144	7	Special Note + 1 to 3
Flush Rail		8002001 / 9831005 / 9812119	5	Special Note + 1 to 3
Gutter Mount		8000350 / 8000351 / 8000352	7	Special Note + 1 to 3
SkyLine, TrackTower or TimberLine with StreamLine Adapter		9813024, 8000199 OR 9813064 WITH 8005042 ADAPTER	6	Special Note + Page 6
RuggedLine		VARIOUS	9 + 10	Special Note + 1 to 4



### **SPECIAL NOTE - ALL PLATFORMS EXCLUDING PLATFORM F.**

Your pivot points have two sets of mounting holes. Where possible, use the centre holes for mounting.

If extra clearance is needed due to platform-to-roof fitment needs, the offset holes can be used.

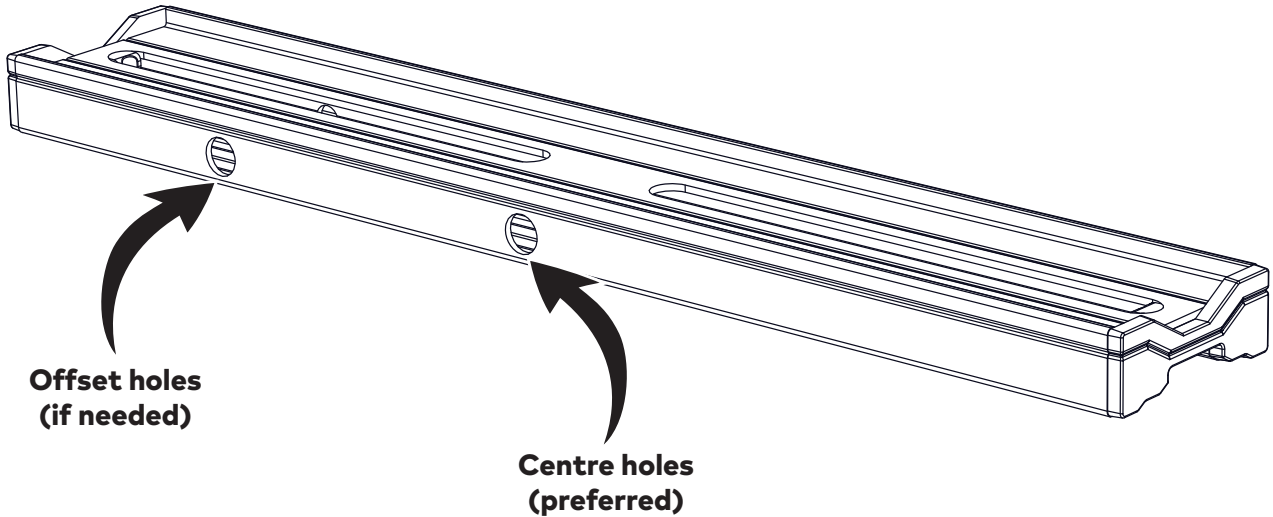

### **SPECIAL NOTE - PLATFORM F.**

Your pivot mounts have two sets of mounting holes at either end of the mount for leg attachments.

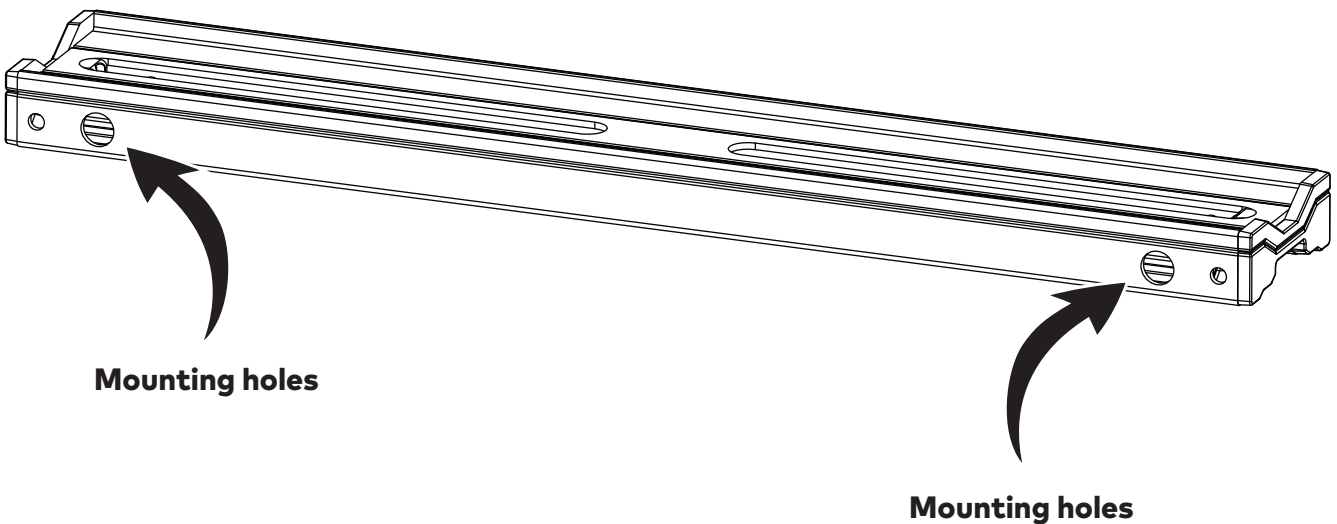

## LEG MOUNTING INSTRUCTIONS FOR FLUSH RAIL LEGS

### 1 REMOVE LEG COVERS.

Using the keys supplied in the LockNLoad leg kit (sold separately), remove all leg covers.

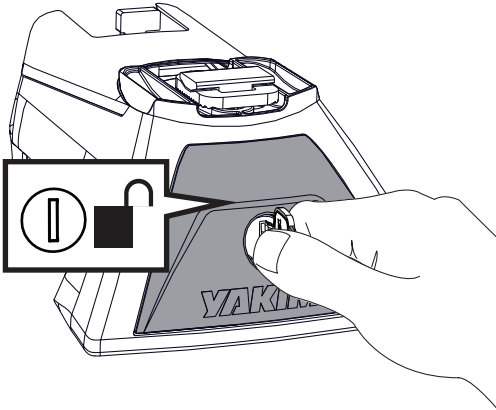

### 2 DISASSEMBLE LEG ASSEMBLIES.

Disassemble leg components as shown and store in a safe place.

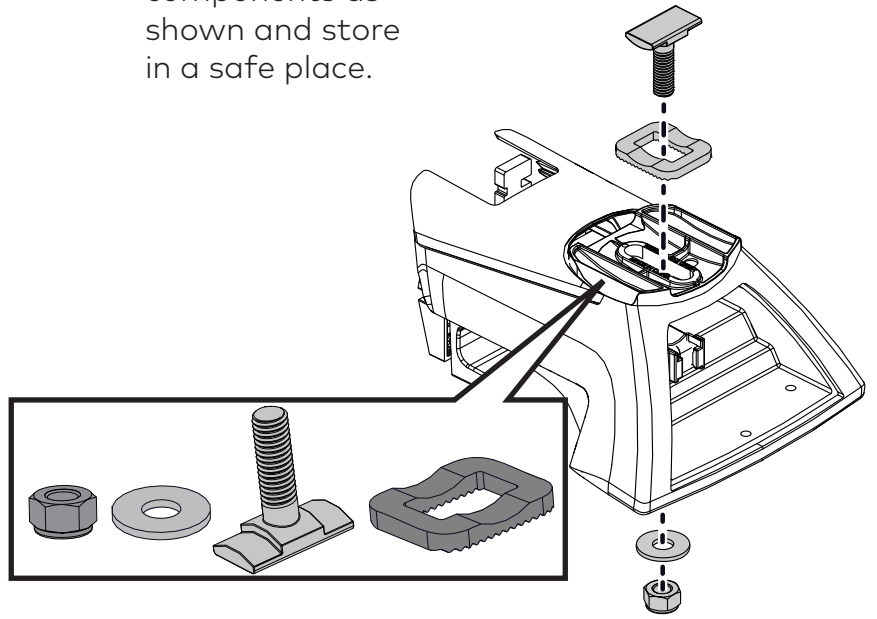

### 3 ASSEMBLE LEGS.

Assemble each leg as shown using one platform mount bracket, M8 coach bolt, M8 washer and M8 nut from the LockNLoad leg kit.

All brackets should be parallel with the base of the leg prior to tightening.

Tighten all M8 nuts to 9 Nm using a 13 mm spanner.

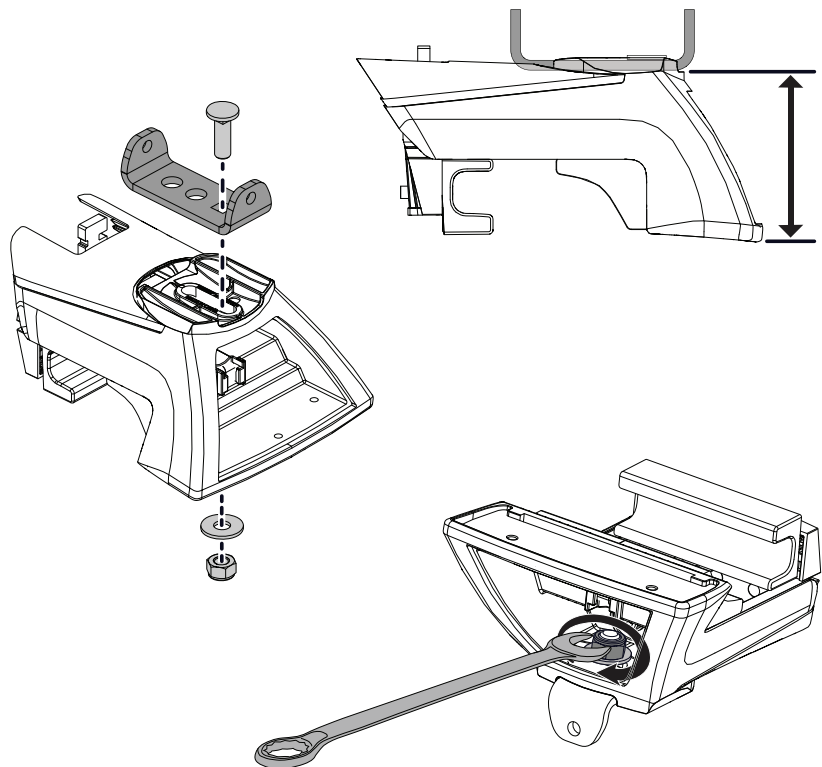

**PLEASE PROCEED TO PIVOT MOUNT INSTALL STEP α.**

## LEG MOUNTING INSTRUCTIONS FOR SKYLINE & TIMBERLINE LEGS WITH STREAMLINE ADAPTER 8005042

**NOTE:** Follow StreamLine adapter instructions for complete hardware installation procedure.

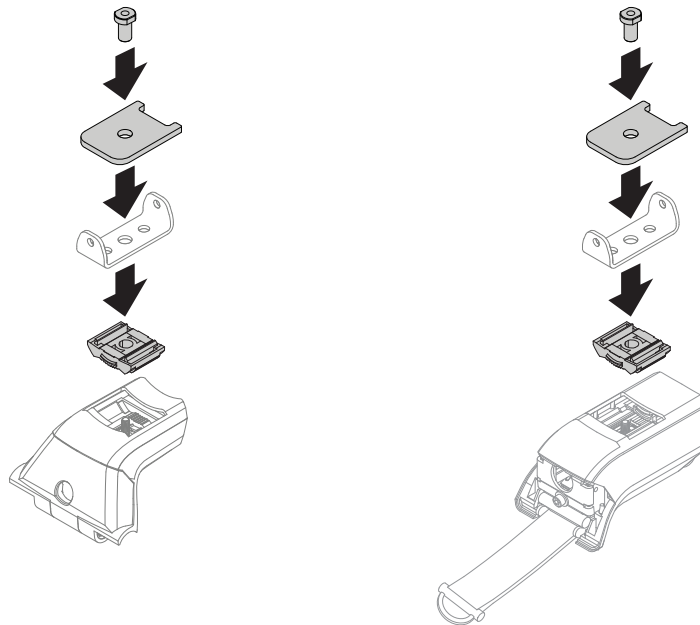

**PLEASE PROCEED TO PIVOT MOUNT INSTALL STEP α.**

## LEG MOUNTING INSTRUCTIONS FOR TRACKTOWER LEGS WITH STREAMLINE ADAPTER 8005042

**NOTE:** Follow TrackTower instructions for complete hardware installation procedure.

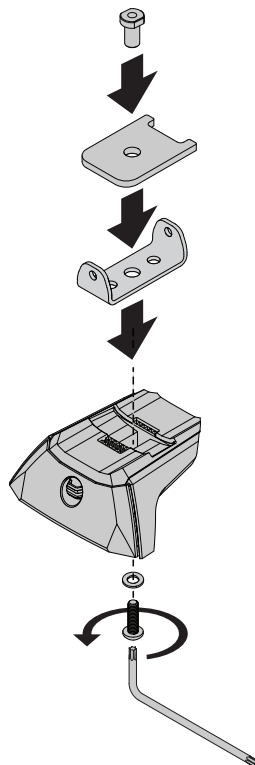

**PLEASE PROCEED TO PIVOT MOUNT INSTALL STEP α.**

## LEG MOUNTING INSTRUCTIONS FOR GUTTER MOUNT & MK1 LEGS

### 1 ASSEMBLE SCREWS.

From the leg kit, assemble an M8 washer onto each M8 hex screw 16 mm as shown.

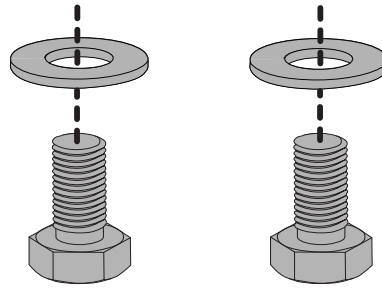

### 2 INSTALL MOUNTING BRACKETS ONTO LEGS.

Insert nut plate (from leg kit) on top of mounting bracket as shown.

Secure using the two screw and washer assemblies from the previous step.

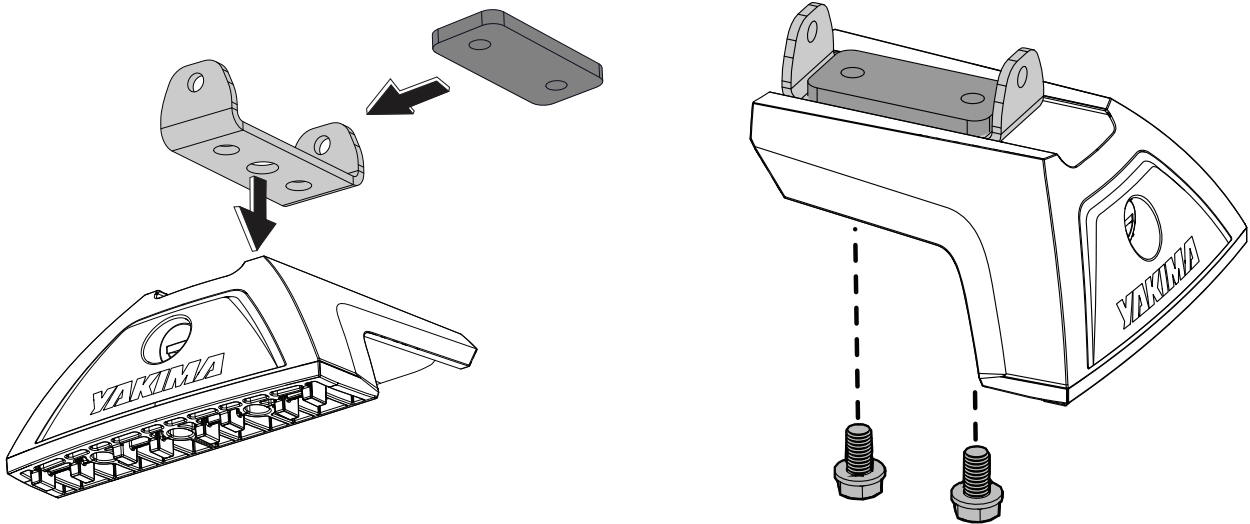

### 3 TIGHTEN PIVOT MOUNTING BRACKETS TO LEGS.

Tighten all M8 hex screws to 7 Nm using a 13 mm socket wrench or spanner.

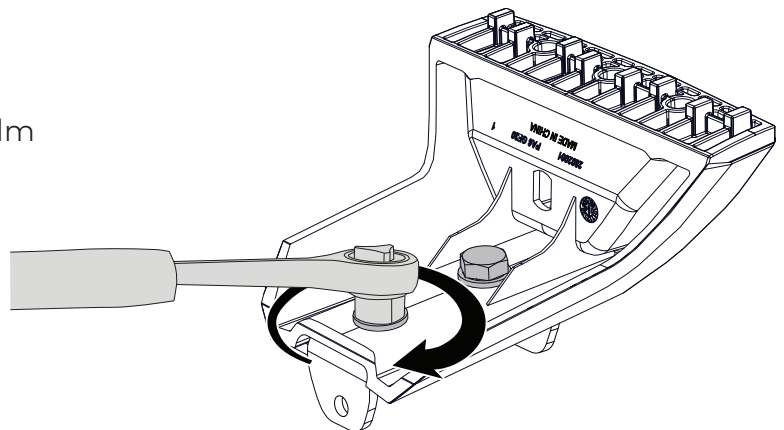

**PLEASE PROCEED TO PIVOT MOUNT INSTALL STEP a.**

## PIVOT MOUNT INSTALL

### a INSTALL PIVOT MOUNT TO LEG.

Insert bushes in the desired location on either side of the pivot mount.

Place the pivot mount onto the mount bracket. Secure using the M6 socket head cap screw with a thin M6 washer on the head side and a thick M6 spacer on the nut side.

Tighten all M6 socket head cap screws to 4 Nm with included 5 mm allen key and nuts with a 10 mm spanner or suitable torque wrench.

#### PIVOT MOUNT INSTALL - ALL PLATFORMS EXCLUDING PLATFORM F.

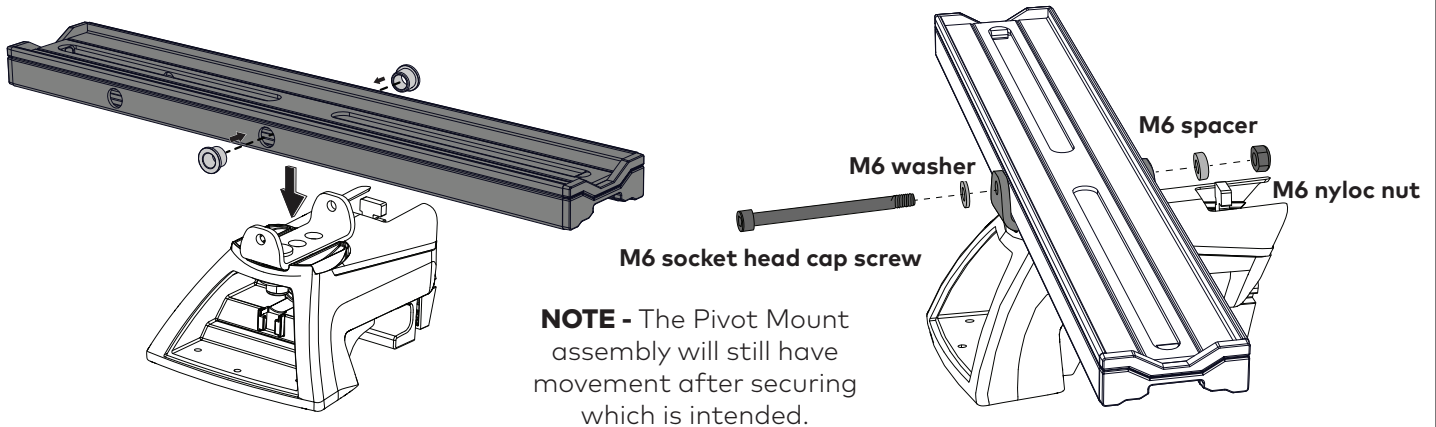

#### PIVOT MOUNT INSTALL - PLATFORM F.

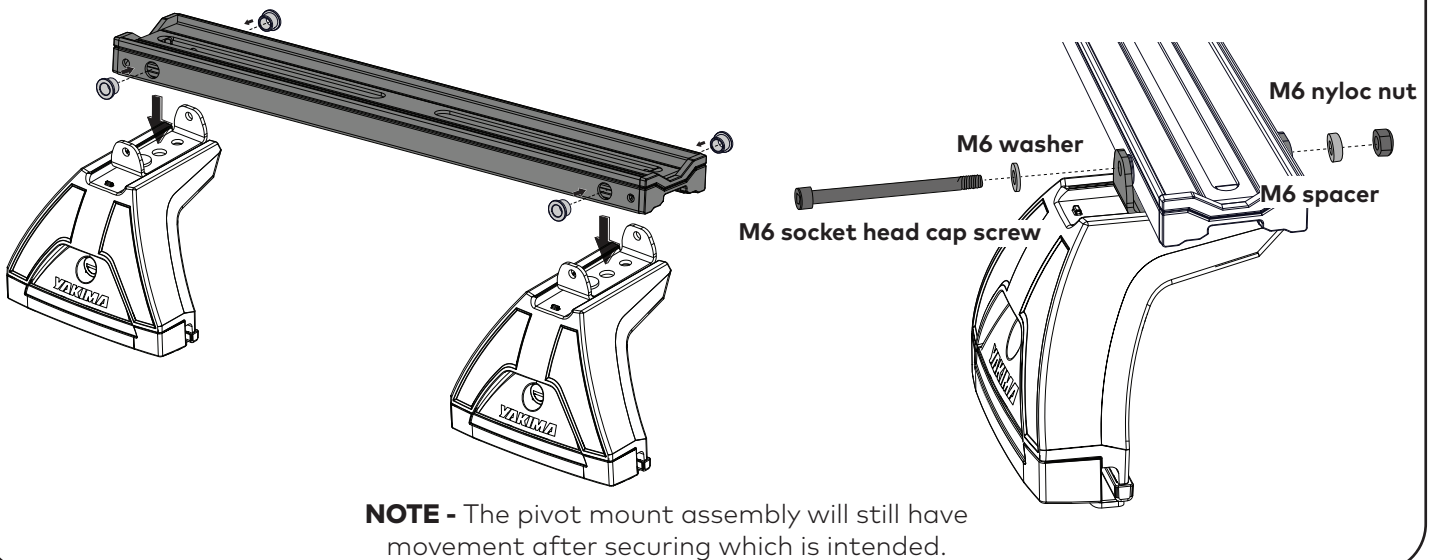

### b MOUNT LEGS TO VEHICLE.

Mount legs to vehicle as per vehicle specific mounting kits (sold separately). Vehicle specific instructions can be viewed and downloaded at our website.

**NOTE -** Bars are not required to install platform.

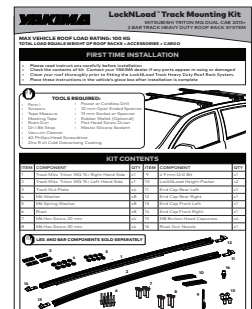

**PLEASE PROCEED TO PAGE 11 FOR  
PLATFORM MOUNTING INSTRUCTIONS.**



# RUGGEDLINE MOUNTING INSTRUCTIONS

## 1 MOUNT RUGGEDLINE TO VEHICLE.

Mount RuggedLine to vehicle as per vehicle specific instructions. Vehicle specific instructions can be viewed and downloaded at our website.

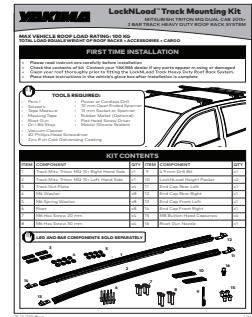

## 2 PIVOT MOUNT INSTALL.

Insert bushes in the desired location on either side of the pivot mount.

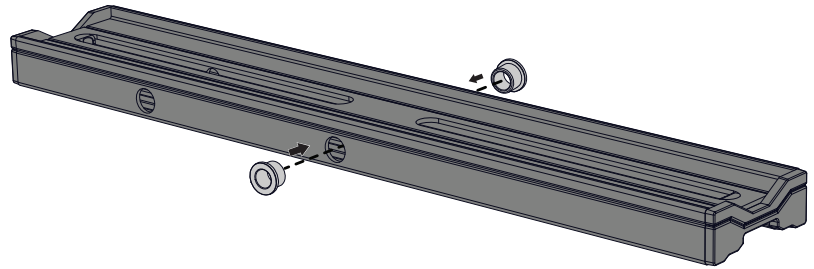

Place a pivot mount on top of each pivot bracket, lining up the bushes on pivot mount with the holes on pivot bracket.

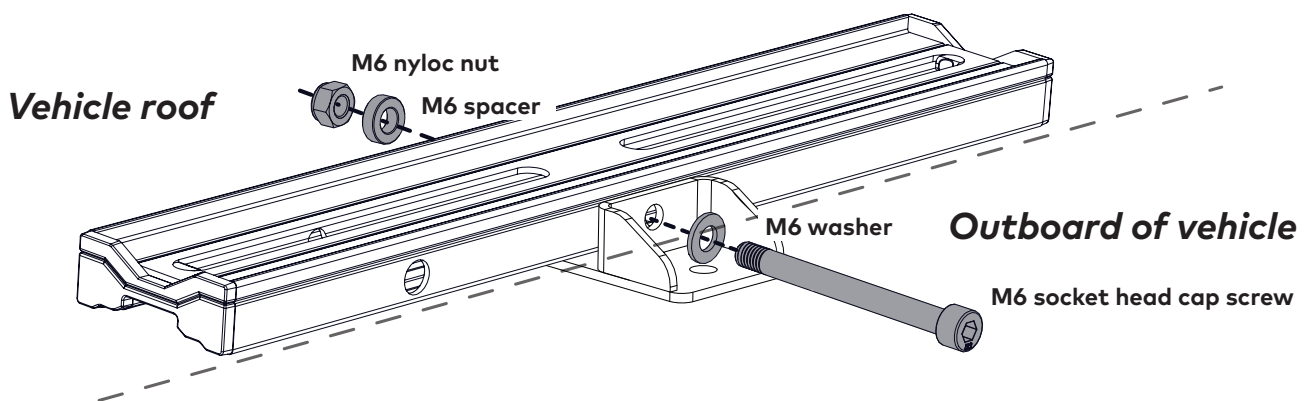
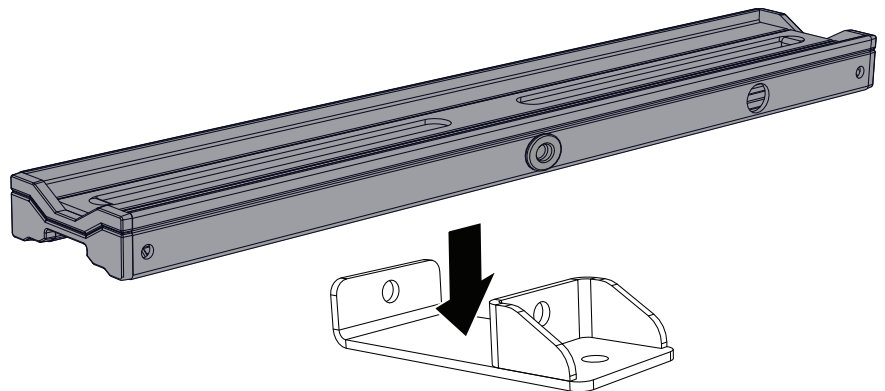

Secure with the M6 socket head cap screw and M6 washer (outboard of vehicle) and M6 spacer and M6 nyloc nut (inboard of vehicle) from this kit **in the order as shown**.

**NOTE -** The pivot mount assembly will still have movement after securing which is intended.

Tighten all M6 socket head cap screws to 4 Nm with included 5 mm allen key and nuts with a 10 mm spanner or suitable torque wrench.

### 3 ASSEMBLE PIVOT BRACKET TO RUGGEDLINE.

Assemble the pivot bracket with pivot mount from the previous step along with the M8 hardware (from RuggedLine kit) as pictured. Complete this for all positions on top of the RuggedLine.

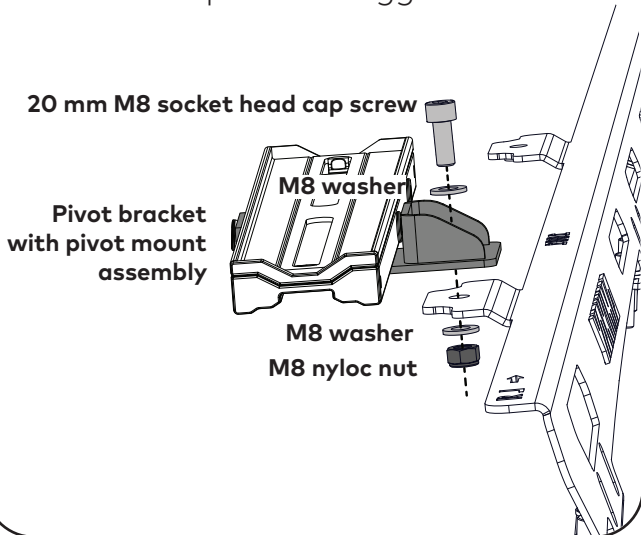

### 4 SECURE PIVOT BRACKET ASSEMBLIES.

Tighten all M8 socket head cap screws with a 6 mm allen key and all nuts with a 13 mm spanner or a suitable torque wrench.

Ensure all M8 socket head cap screws are tightened to 7 Nm.

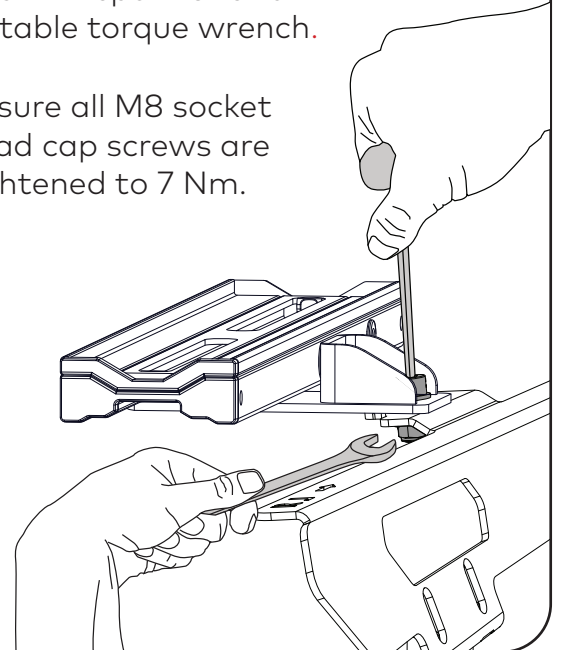

**PLEASE PROCEED TO PAGE 11 FOR PLATFORM MOUNTING INSTRUCTIONS.**

## PLATFORM MOUNTING INSTRUCTIONS ALL PLATFORMS EXCLUDING PLATFORM F

### 1 LIFT PLATFORM ONTO VEHICLE.

With the help of an assistant, carefully lift the platform up and onto pivot mounts on the vehicle roof. Centre platform evenly on the legs so there is an equal overhang on sides and ideally on the front and rear.

**NOTE - Wind deflector is to be at the front of the vehicle.**

**NOTE - For hatch vehicles ensure to position the platform so that there is adequate hatch clearance when fully opened.**

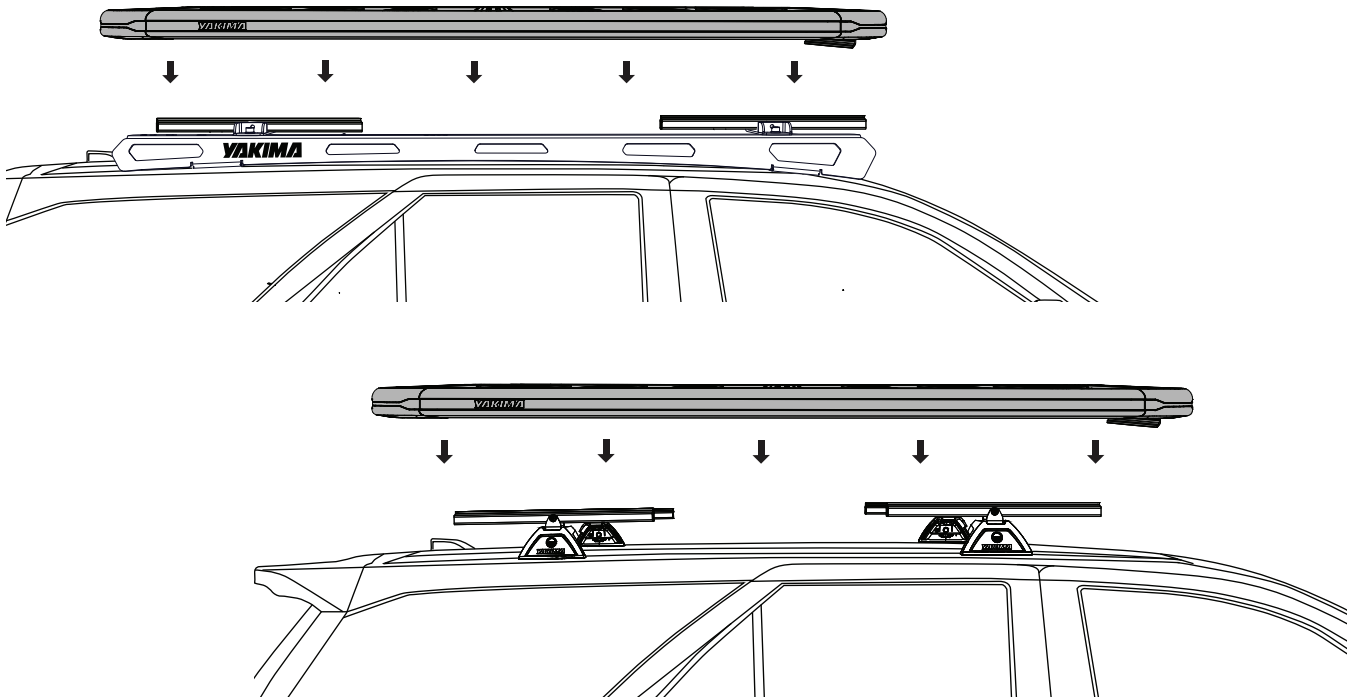

### 2 MAXIMUM OVERHANG.

The maximum unsupported distance from pivot mount is ONE slat on either end as shown.

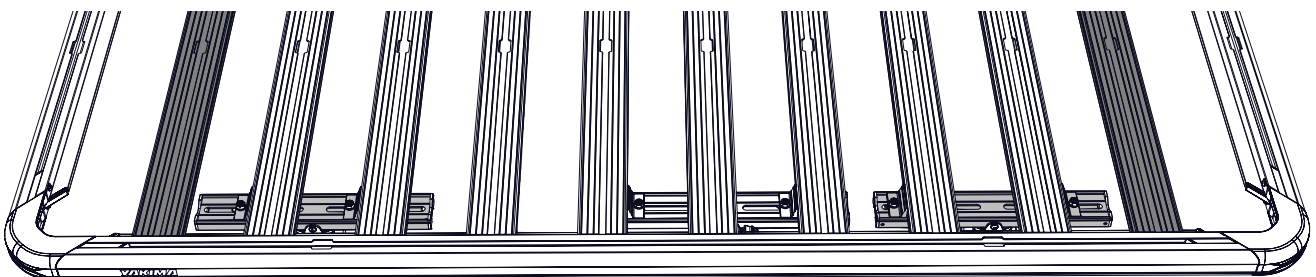

### 3 ROOF CLEARANCE.

The platform supports ideally should be fixed using the centre of the three holes. However, these can be offset left or right depending on the vehicle's roof or usage requirements. For instance, to prevent interference with an antenna in the center of a vehicle roof (e.g. Nissan Navara NP300, Ford Ranger).

Loosen the three M8 nuts along the centre support and remove the single M6 button head cap screw. Reinstall the M6 button head cap screw in the desired location and retighten all M8 nuts to 7 Nm and the M6 button head cap screw to 4 Nm.

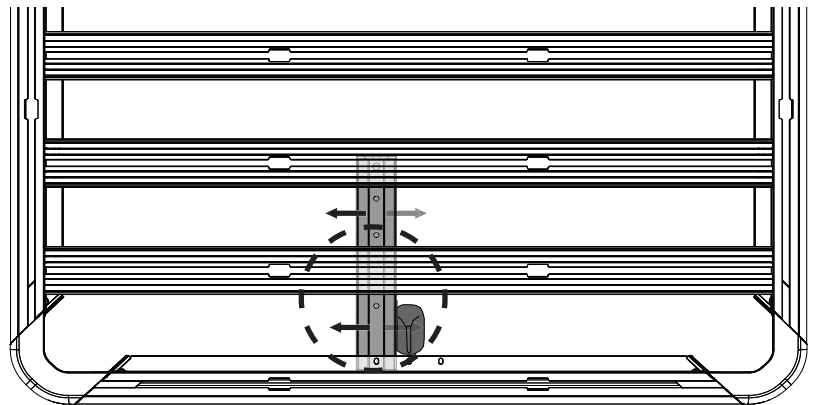
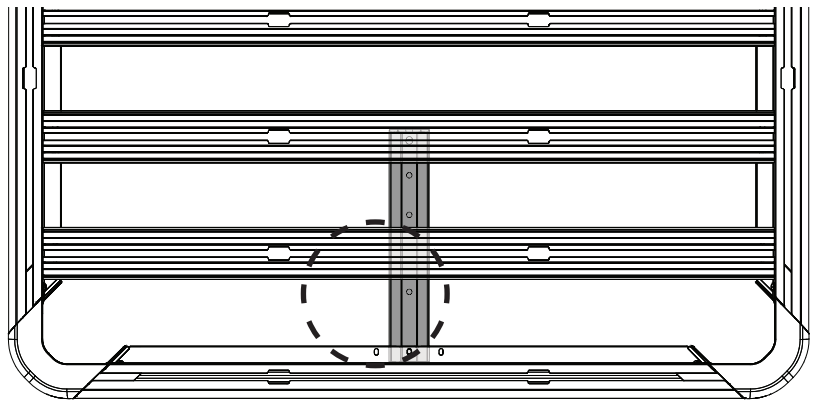

### 4 INSERT T-BOLTS INTO PIVOT MOUNTS.

Insert one M8 t-bolt into pivot mount channel on either side of each leg. Twist to lock into place. The larger the distance between each pair of M8 t-bolts the better. See images for possible location scenarios:

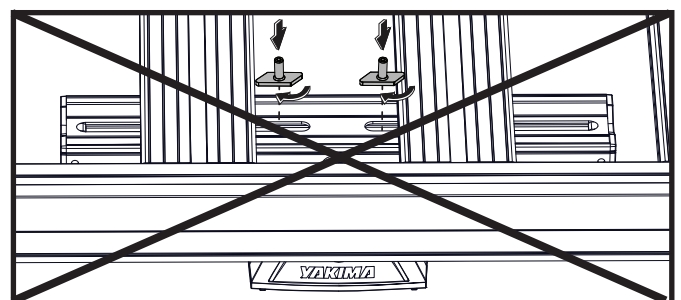
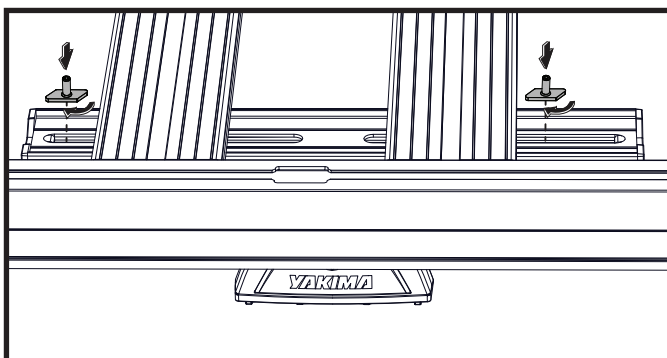
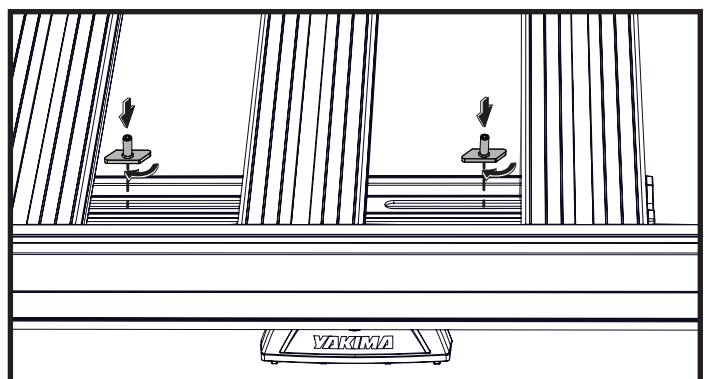
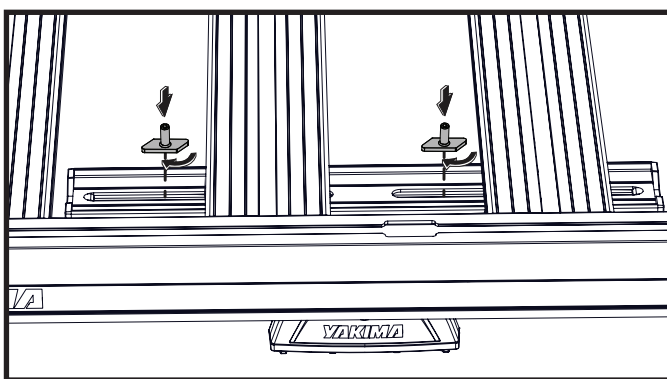

**Do not use this configuration**

## 5 SECURE PIVOT MOUNTS TO PLATFORM.

Secure pivot mounts to platform slats using one slat clamp, one M8 washer and one M8 nyloc nut onto each M8 t-bolt as shown.

Tighten all nuts to 7 Nm using a 13 mm socket wrench or spanner.

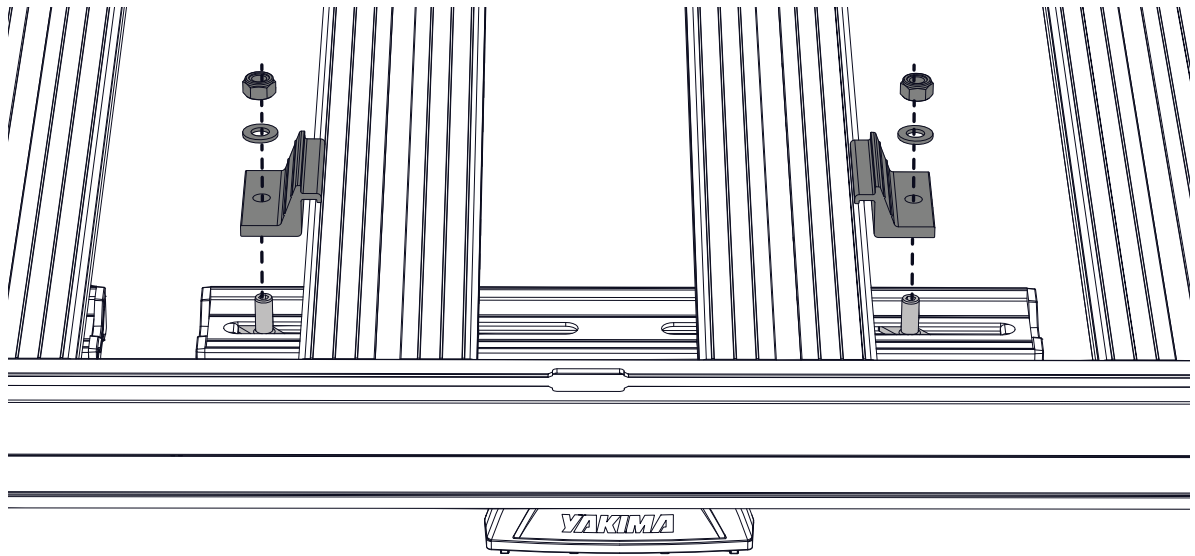

**NOTE - Do not to over tighten slat clamps past 7 Nm as this may reduce clamping force.**

## 6 PLATFORM MOUNTING COMPLETE.

Check that platform has been secured correctly as per the mounting instructions.

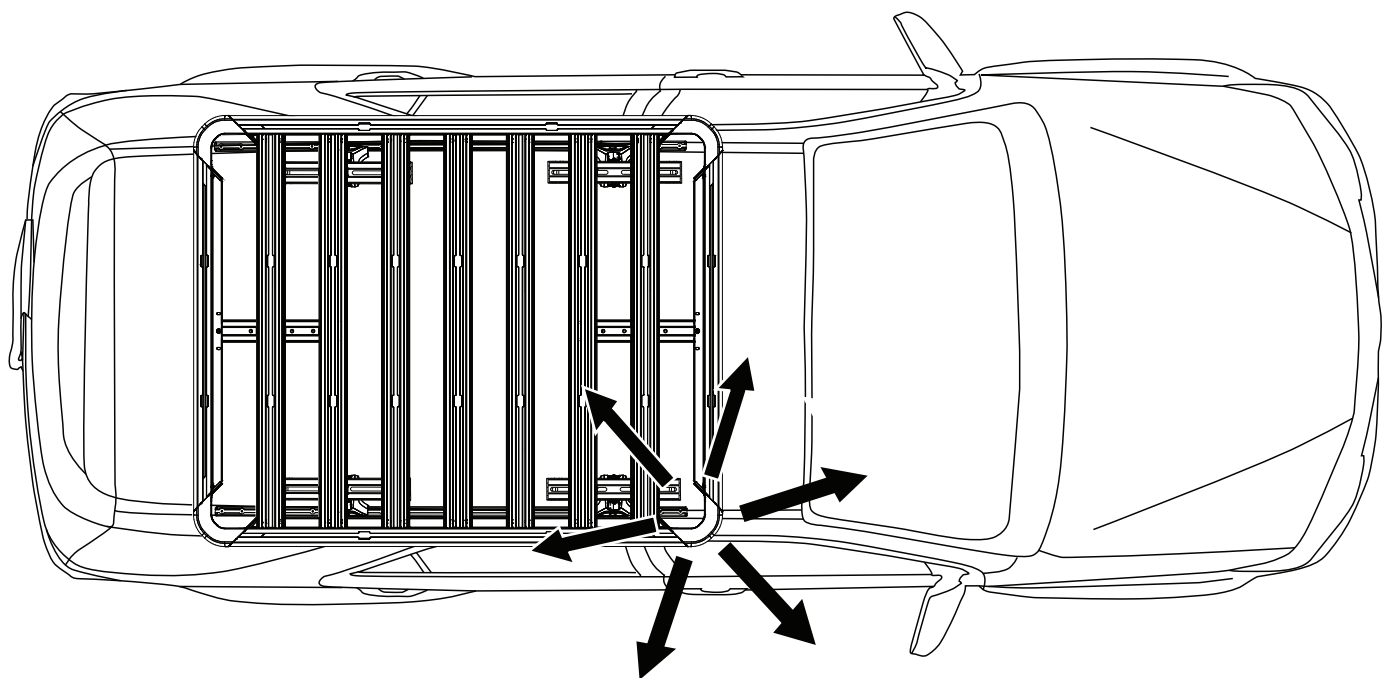

**NOTE - 7 slat platform shown - indicative sizes A and B.**

# PLATFORM MOUNTING INSTRUCTIONS

## PLATFORM F

### 1 LIFT PLATFORM ONTO VEHICLE.

With the help of an assistant, carefully lift the platform up and onto the pivot mounts on vehicle roof. Centre the platform evenly on the legs so there is an equal overhang on sides and ideally on the front and rear.

**NOTE - Wind deflector is to be at the front of the vehicle.**

**NOTE - For hatch vehicles ensure to position the platform so that there is adequate hatch clearance when fully opened.**

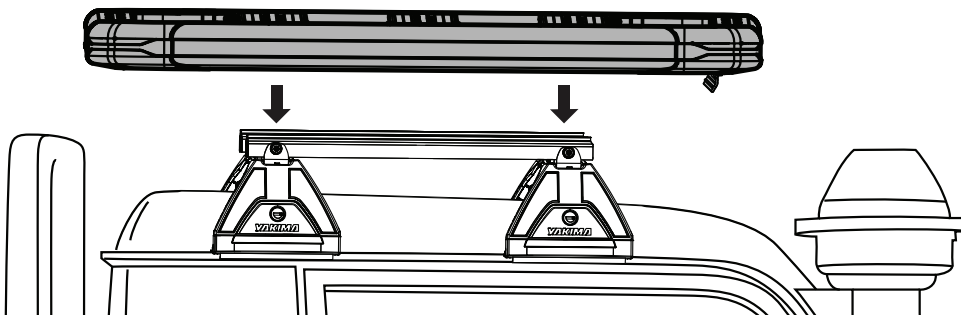

### 2 INSERT T-BOLTS INTO PIVOT MOUNTS.

Insert one M8 t-bolt into pivot mount channel next to each platform slat side as pictured. Twist to lock into place.

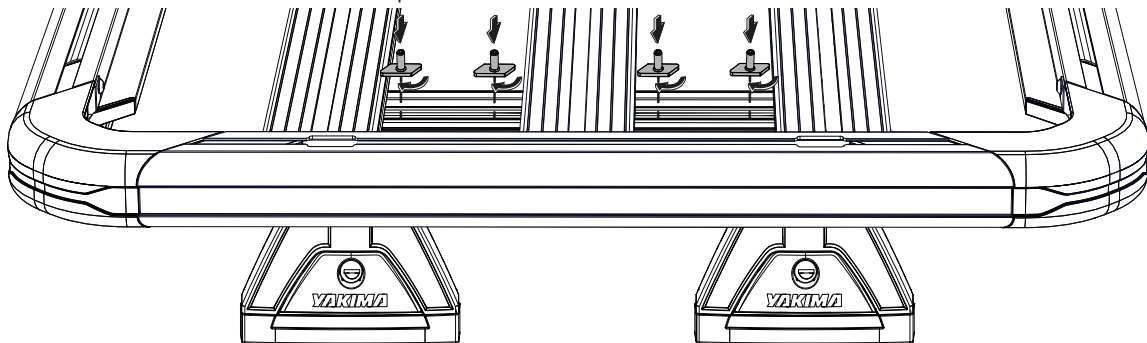

### 3 SECURE PIVOT MOUNTS TO PLATFORM.

Secure pivot mounts to platform slats using one slat clamp, one M8 washer and one M8 nyloc nut onto each M8 t-bolt as shown.

Tighten all nuts to 7 Nm using a 13 mm socket wrench or spanner.

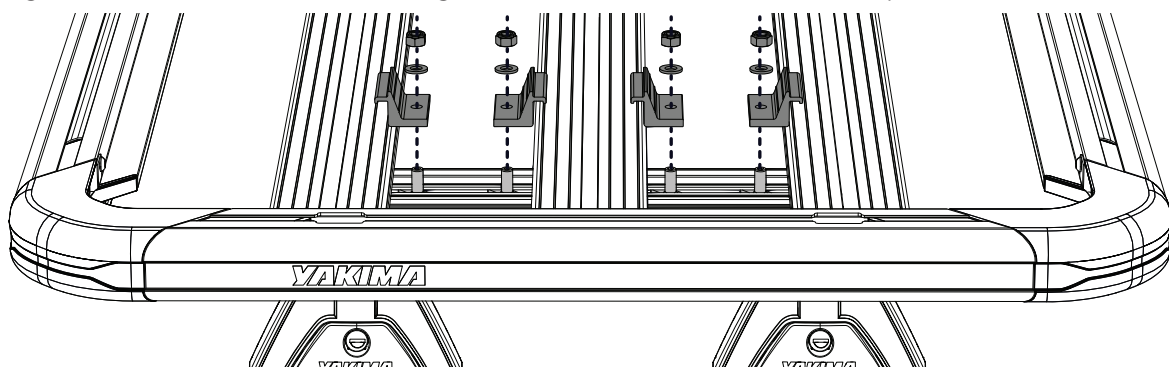

**NOTE - Do not to over tighten slat clamps past 7 Nm as this may reduce clamping force.**

**4****PLATFORM MOUNTING COMPLETE.**

Check that platform has been secured correctly as per the mounting instructions.

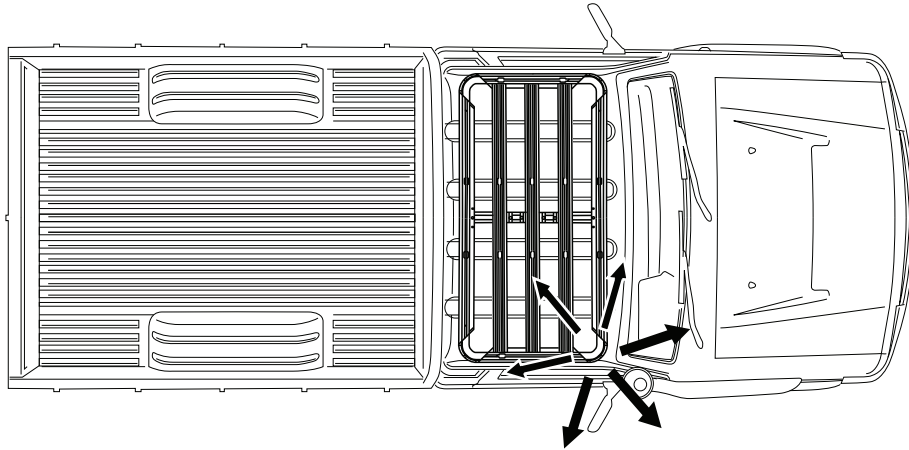
**WIND DEFLECTOR REMOVAL**

**NOTE:** The wind deflector can be removed to suit certain anchors/accessories to be used with the front extrusion. This is done by simply peeling the part out of the slot, starting at one end and working across the length of the deflector.

Installation is the reverse and should be confirmed by hearing an audible 'CLICK' when the deflector is fully installed.

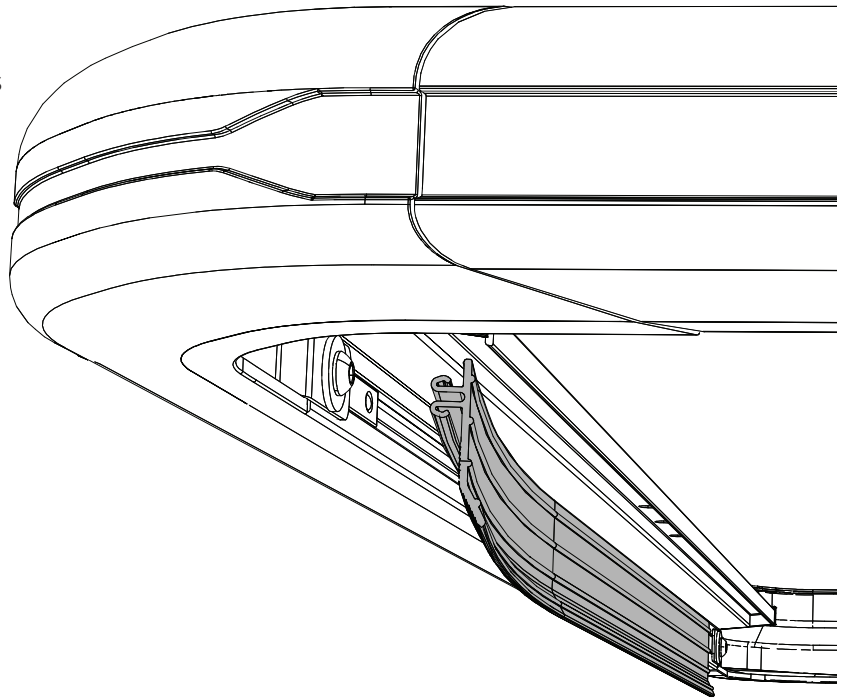



[www.yakima.com.au](http://www.yakima.com.au)  
[www.yakima.co.nz](http://www.yakima.co.nz)  
[www.yakima.com](http://www.yakima.com)  
[www.yakima.eu](http://www.yakima.eu)

**YAKIMA AUSTRALIA PTY LTD**

17 Hinkler Court  
Brendale, QLD 4500  
Australia  
1800 143 548

**YAKIMA PRODUCTS, INC.**

4101 Kruse Way  
Lake Oswego, OR  
97035-2541  
USA  
888 925 4621  
[yakima.com/support](http://yakima.com/support)